

# SIRRUS



Heating technology since 1959

# *Instruction Manual* *for models*

---

## **RKA 25**

---

*Premix condensing boiler*  
*with storage cylinder*



*The code of practice for the installation,  
commissioning & servicing of gas fires and wall heaters*

**SEDBUK BAND A**

**GAS COUNCIL NUMBER: 47-651-21**

*Installation, operating, commissioning and maintenance instructions.*

CE 0694

TG05A095.A0306



**1. General information**

1.1 General Installation Information	page	1
1.2 Product conformity	page	3

**2. Technical characteristics**

2.1 Technical data	page	4
2.2 Dimensions	page	5
2.3 Internal parts of the boiler	page	6
2.4 Water circuit	page	7
2.5 Circulation pump head graph	page	8
2.6 Printed circuit board	page	9
2.7 Control panel	page	10

**3. Installing the appliance (authorised personnel)**

3.1 Reference standard	page	11
3.2 Unpacking	page	12
3.3 Installing the boiler	page	13
3.4 Water connections	page	14
3.5 Central heating circuit	page	15
3.6 Condensate drain	page	16
3.7 Discharge piping	page	17
3.8 D.H.W circulating loop	page	18
3.9 Gas connection	page	19
3.10 Electrical connections	page	19
3.11 Room thermostat - outdoor sensor connections	page	20
3.12 Remote control connection	page	21
3.13 Flue connections	page	24

**4. Initial start up (authorised personnel)**

4.1 General warnings (flushing the system)	page	30
4.2 Filling the system	page	31
4.3 Flushing the system	page	32
4.4 Filling the condensate trap	page	32
4.5 Starting up the boiler	page	33

**5. Commissioning the appliance** (authorised personnel)









5.1	Parameter table	page	34
5.2	Parameter programming - regulating the gas pressure	page	35
5.3	Gas data	page	40
5.4	Regulating the stepped ignition sequence	page	41
5.5	Converting the boiler to a different gas type	page	42

**6. Servicing the appliance** (authorised personnel)

6.1	General warnings	page	43
6.2	Boiler inspection	page	43
6.3	Maintenance for unvented components	page	44
6.4	Accessing the boiler	page	45
6.5	Draining the central heating and domestic hot water system	page	46
6.6	Wiring diagrams	page	47
6.7	Troubleshooting	page	48
6.8	Diagnostics	page	49
6.9	Parts list	page	50

# 1. GENERAL INSTRUCTIONS

## 1.1 General warnings

-  Professionally qualified personnel in accordance with current laws and standards and in line with the manufacturer's instructions must install the appliance. To check for authorised qualified engineers please contact CORGI 01256-372400
-  The term professionally qualified personnel refers to persons possessing the appropriate technical competencies within the sector with regard to the installation and servicing of domestic and industrial central heating plants and domestic hot water production systems as provided for by current standards.
-  The commissioning of the boiler and any subsequent works carried out on the appliance must be effected by an appropriately qualified technician or an approved Radiant Helpline Service Centre.
-  The appliance must be used solely for the purpose for which it has been designed and manufactured: central heating and domestic hot water production. Any other use is deemed as improper and as such dangerous. Under no circumstances will the manufacturer be held responsible for damage or injury to persons or animals caused by errors in the installation and/or use of the appliance, or through non-compliance with current local and national standards and/or the manufacturer's instructions.
-  The installation, operation and maintenance manual forms an integral and essential part of the product and must be kept near the appliance always.
-  This Manufacturer Installation and Maintenance manual must not be removed on completion of the installation; must be kept in a safe place and made available for future reference. This Manual must be left along with the Benchmark commissioning booklet with the boiler as Regulation 29 of the HSC Gas safety (installation and use) Regulations 1998.
-  The warnings contained in this chapter have been written for the appliance user, the installer and the service engineer.
-  The "operating instructions" chapter of this manual must be read carefully as it provides information on the operation and the operating limits of the appliance.
-  This appliance must be used exclusively in an un-vented central heating system.
  - After the removal of all the packaging, check that the appliance has not been damaged. In case of doubt, do not attempt to use the product but refer to the supplier. Packing materials (cardboard box, wooden crate, nails, staples, plastic bags, polystyrene, etc.) must not be left within reach of children in that these items represent a potential hazard and must be disposed of in a responsible manner.
  - Before carrying out any cleaning or maintenance operations, disconnect the appliance from the mains electricity supply by switching off at the main switch and/or any other isolating device.
  - Do not obstruct the air intake or heat dissipation grills.
  - Do not obstruct the openings of the air intake or flue ducts.
  - In the case of a fault and/or malfunction in the appliance, shut down the system. Do not interfere with or attempt any repairs. Call for professionally qualified technical assistance only. Radiant Helpline UK 0870 770 0414
  - Any warranty repairs to the appliance must be carried out exclusively by the manufacturer's authorised service centre using original spare parts. Non-compliance with the above requirements may compromise the safety of the appliance and invalidate the warranty. In order to guarantee the efficiency of the appliance and its correct operation, it must be serviced regularly by professionally qualified personnel in line with the manufacturer's instructions.
  - When the appliance is no longer required for use, any parts that may constitute potential sources of danger must be rendered harmless.
  - Only original accessories or optional extras (including electrical parts) must be used with the appliance.

- Should there be a smell of gas present in the room where the appliance is installed, **DO NOT** attempt to activate any electric switches, telephones or any other equipment that may cause sparks. Open doors and windows immediately to create a current of air and ventilate the room. Shut-off the main gas supply valve (at the meter), or on the cylinder in the case of bottled gas, and call an authorised service centre.
- **Do not attempt to interfere with the appliance in any way.**
- Central heating systems fitted with radiator thermostats must be fitted with an external automatic bypass.
- As dictated by current legislation, this appliance **must be installed exclusively by qualified personnel** in accordance with standards **UNI-CIG 7129** and **7131**, and any amendments or updates, and in line with the requirements of the local fire service and gas supplier. Before starting the boiler for the first time, make sure that it is connected to a water supply and central heating system compatible with its performance characteristics. The room must be ventilated by means of an air intake (refer to UNI 7129/92 and UNI 7129/95 FA).
- **Check the technical data reported on the packing and on the rating plate** located on the inside of the front casing. Also check that the burner is appropriate for the type of gas to burn.
- **Make sure that the pipes and fittings used for the gas service are perfectly tight and that there are no gas leaks.**
- Prior to start-up, the central heating pipes should be flushed to remove any residues that could compromise the operation of the appliance.
- The appliance can be regarded as being electrically safe when it has been connected to an efficient earth system installed in accordance with the requirements of current safety standards (Standard CEI 64-8 Electrical Installations).
- This fundamental safety requirement must be checked and verified. In case of doubt, have the electrical system checked by a qualified electrician. The manufacturer will not be held liable for any damage or injury caused as a result of an ineffective or non-existent earth system.
- The domestic power supply must be checked by a qualified electrician to ensure that it can support the maximum power absorption of the appliance, as indicated on the rating plate. In particular, make sure that the cable ratings are adequate for the power absorbed.
- Do not use adapters; multiple sockets or extension leads to connect the appliance to the mains power supply.
- The appliance must be connected to the mains power supply through an appropriate electrical isolator in accordance with the current wiring regulations.
- When using an electrical appliance, a few fundamental rules must be observed:
  - Do not touch the appliance with damp or wet parts of the body or when barefoot
  - Do not pull on the electric wires
  - Do not leave the appliance exposed to atmospheric elements (rain, sun, etc.) unless these conditions have been expressly provided for.
  - Do not allow the appliance to be used by children or anyone unfamiliar with its operation.
  - The user must not replace the power supply cable.
  - If the cable is damaged in any way, switch off the appliance and have the cable replaced by a suitably qualified electrician.
- **Radiant Helpline UK 0870 770 0414**

## 1.2 Product conformity

RADIANT BRUCIATORI S.p.A. declare that all its products are manufactured to a high specification and in compliance with the relevant standards.

All **RADIANT** boilers are **CE** certified and possess technical and functional characteristics that comply with the following standards:

UNI-CIG 7271 (April 1988)

UNI-CIG 9893 (December 1991)

UNI EN 297 for GAS-FIRED CENTRAL HEATING BOILERS TYPE B OF NOMINAL HEAT INPUT  $\leq 70$  kW

EN 483 for GAS-FIRED CENTRAL HEATING BOILERS TYPE C OF NOMINAL HEAT INPUT  $\leq 70$  kW

UNI EN 677 for GAS-FIRED CENTRAL HEATING BOILERS. SPECIFIC REQUIREMENTS FOR CONDENSING BOILERS WITH NOMINAL HEAT INPUT  $\leq 70$  kW

The gas-fired boilers also comply with the following directives:

GAS APPLIANCES DIRECTIVE 90/396 CEE for CE compliance

LOW VOLTAGE DIRECTIVE 73/23 CEE

ELECTROMAGNETIC COMPATIBILITY DIRECTIVE 89/336 CEE

BOILER EFFICIENCY DIRECTIVE 92/42 CEE

The materials used such as copper, brass, stainless steel, etc. form a compact, homogeneous, highly functional unit that is easy to install and simple to operate. In its simplicity, the wall-mounted appliance is equipped with all the appropriate accessories required to make it a fully independent boiler capable of satisfying domestic hot water production and central heating needs. All boilers are fully inspected and are accompanied by a quality certificate, signed by the inspector, and a guarantee certificate. This manual must be kept in a safe place and must **accompany the boiler at all times**.

**RADIANT BRUCIATORI S.p.A. will not be held responsible for any misinterpretation of this manual resulting from the inaccurate translation of same.**

**RADIANT BRUCIATORI S.p.A. will not be held responsible for the consequences in the case of non-observance of the instructions contained in this manual or in the case where actions not specifically described herein are undertaken.**

## 2. TECHNICAL CHARACTERISTICS

### 2.1 Technical data

Appliance Model		RKA 25
<b>Technical Data</b>		
CE certification no.	n°	0694BN3485
Flue category (UNI10642)		C13, C33, C43, C53, C83
Heat Input max	kW	25
Heat Input min	kW	9
Heat Output max (80/60°)	kW	24.60
Heat Output max (50/30°)	%	26.68
Heat Output min (80/60°)	%	8.73
Efficiency 100% load (80/60°)	kW	98,40
Efficiency 100% load (50/30°)	kW	106,70
Efficiency 30% load (80/60°)	%	100.10
Efficiency 30% load (50/30°)	%	106,30
Gas Directive 92/42/ECC - Efficiency marking	stars	4
NOx class (European Standard UNI EN 297 – pr A5)	class	5
Sedbuk	band	A
<b>Heating circuit</b>		
Central heating water temperature setting (min-max)	°C	30-80
Max. Heating temperature	°C	80
Max. Working pressure (heating)	Bar	2.5
Min. working pressure (heating)	Bar	0.3
Expansion vessel capacity	Litres	10
<b>Domestic hot water</b>		
D.H.W. temperature setting	°C	35-60
Max. Hot water working pressure	bar	6
Min. Hot water working pressure	bar	0.5
Continuous hot water supply - $\Delta t$ 30° - mixed water	litres/h	726
Max. continuous hot water supply - $\Delta t$ 30° mixed water - first 10 minutes	litres	141
Storage cylinder capacity	litri	20
<b>Dimensions</b>		
Width	mm	490
Height	mm	900
Depth	mm	450
Weight	kg	70
<b>Hydraulic connections</b>		
Flow connection	Ø	3/4"
Return connection	Ø	3/4"
Cold water connection	Ø	1/2"
Hot water connection	Ø	1/2"
Gas connection	Ø	1/2"
<b>Flue systems</b>		
Horizontal-Coaxial flue system - <b>kit K</b>	Ø	100/60
Max. flue length	m	5
Twin pipe flue system - <b>kit H</b>	Ø	80/80
Max. flue length	m	50
Vertical-Coaxial flue system - <b>kit V</b>	Ø	100/60
Max. flue length	m	5
<b>Gas Supply</b>		
<b>Natural Gas G 20</b>		
Inlet pressure	mbar	20
Gas consumption	m3/h	2.83
<b>Liquid Butane Gas G 30</b>		
Max. Inlet pressure	mbar	30
Gas consumption	kg/h	2.11
<b>Liquid Propane Gas G 31</b>		
Max. Inlet pressure	mbar	37
Gas consumption	kg/h	2.08
<b>Electrical supply</b>		
Power supply	V/Hz	230/50
Maximum Power consumption	W	180
Electrical protection	IP	IPX4D



## 2.2 Dimensions

### mod. RKA 25

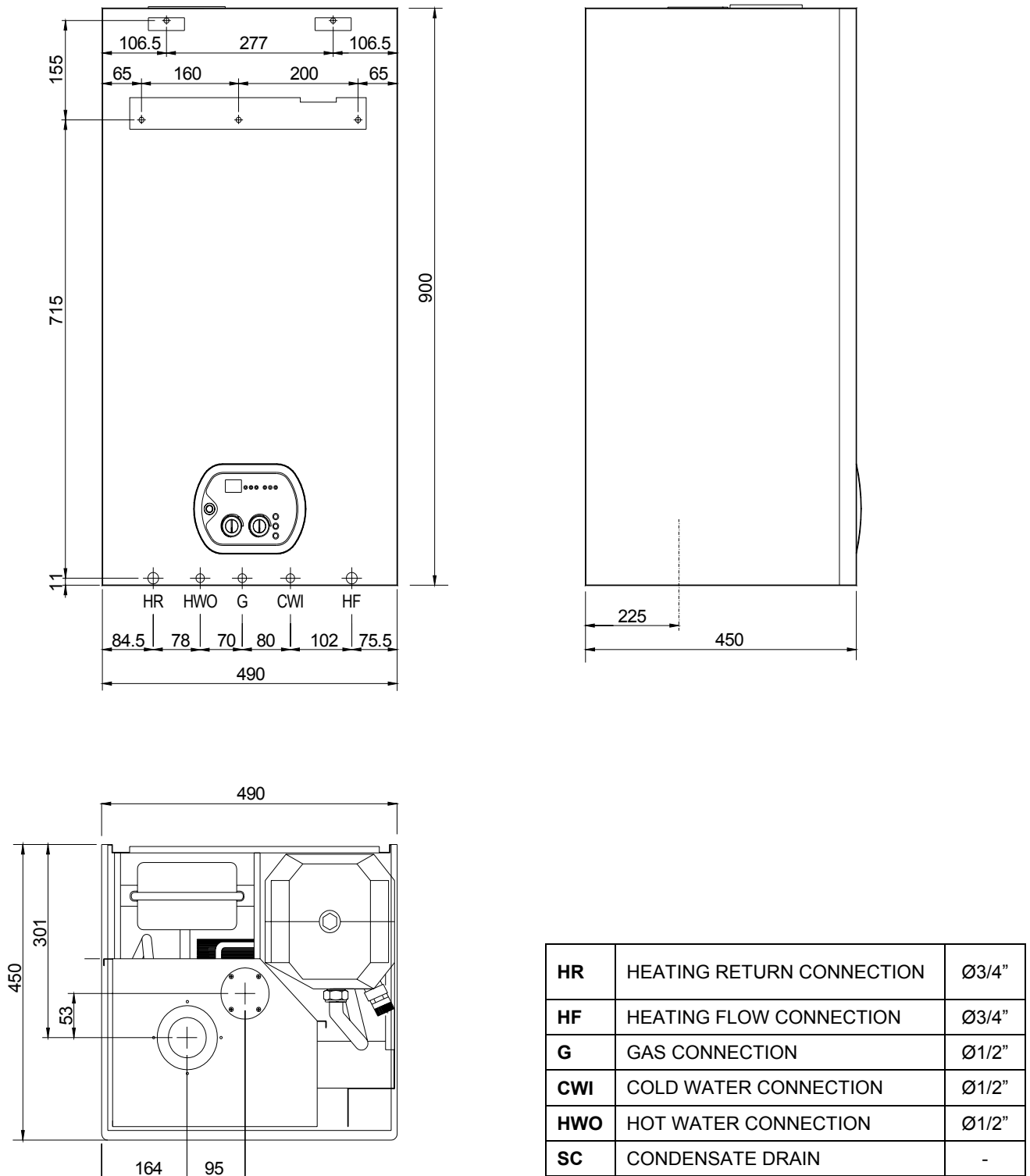

## 2.3 Internal parts of the boiler

### mod. RKA 25

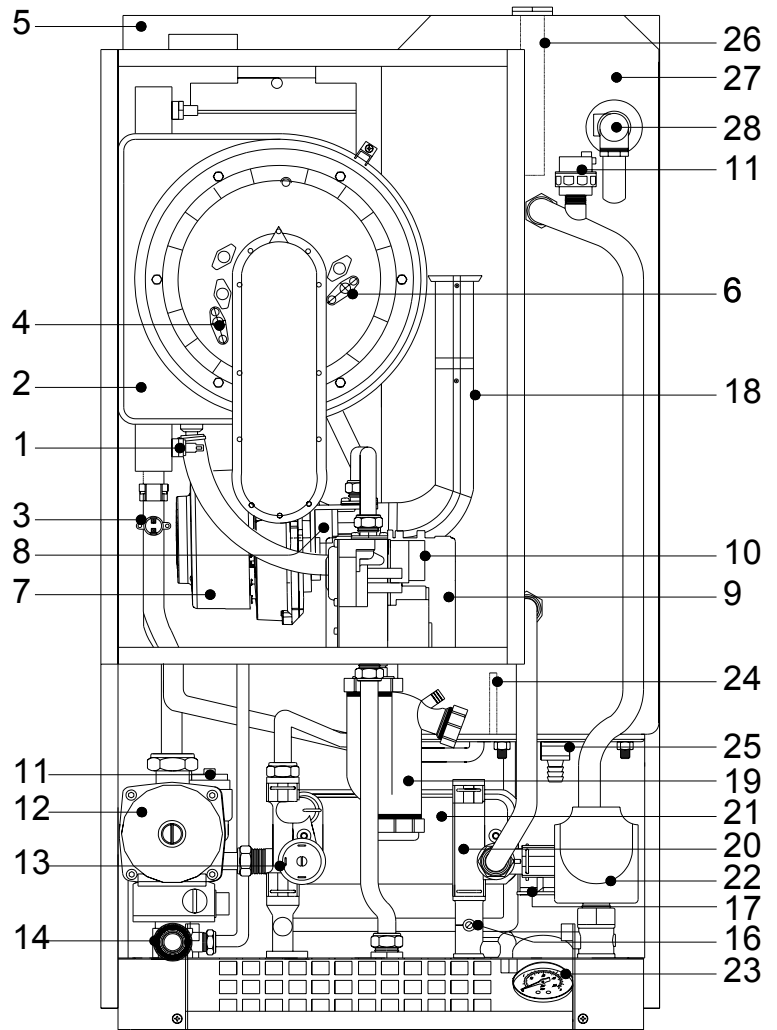

#### LEGEND

1. HEATING SENSOR
2. CONDENSING EXCHANGER
3. HEATING SAFETY THERMOSTAT
4. IGNITION ELECTRODE
5. FRAME
6. FLAME IONISATION ELECTRODE
7. FAN
8. MIXING GROUP
9. ELECTRONIC IGNITION BOARD
10. ELECTRONIC GAS VALVE VK4105 A 1001
11. AUTOMATIC AIR VENT
12. 3-SPEED CIRCULATION PUMP WITH AIR VENT
13. WATER PRESSURE SWITCH
14. HEATING CIRCUIT 3 bar PRESSURE RELIEF VALVE
15. DRAINING TAP
16. FLOW LIMITER
17. BY-PASS
18. AIR COMBUSTION INTAKE PIPE
19. WATER TRAP SIPHON
20. ELECTRONIC FLOWSWITCH
21. FLAT PLATE TYPE EXCHANGER
22. 3-WAY DIVERTER VALVE
23. WATER PRESSURE GAUGE
24. HOT WATER SENSOR
25. BOILER DRAINING TAP
26. ANODE
27. 25 LITRE WATER STORAGE TANK
28. 7 ATE PRESSURE RELIEF VALVE (HOT WATER)

## 2.4 Water circuit

### LEGEND

1. PRIMARY CONDENSING HEAT EXCHANGER
2. PREMIX BURNER UNIT (GAS MANIFOLD + BURNER)
3. CONDENSATE DRAIN PIPE
4. IGNITION ELECTRODE
5. SENSOR ELECTRODE
6. ELECTRIC FAN
7. VENTURI
8. ELECTRONIC IGNITION PCB
9. ELECTRONIC GAS VALVE
10. HEATING CIRCUIT 3 BAR SAFETY VALVE
11. AUTOMATIC AIR VENT
12. HEATING SAFETY THERMOSTAT
13. HEATING SENSOR
14. CIRCULATION PUMP WITH AIR VENT
15. WATER PRESSURE SWITCH
16. FLUE DUCT CONNECTION CHAMBER
17. EXHAUST TEST SOCKET
18. EXPANSION TANK
19. AIR INTAKE DUCT
20. CONDENSATE TRAP
21. PRESSURE GAUGE
22. BYPASS
23. CONDENSATE TRAP OVERFLOW
24. SYSTEM DRAIN VALVE
25. SEALED CHAMBER CASING
26. FLOW LIMITER
27. ELECTRONIC FLOW SWITCH
28. D.H.W. HEAT EXCHANGER
29. 3-WAY DIVERTER VALVE
30. D.H.W. SENSOR
31. HOT WATER SENSOR
32. 7 ATE PRESSURE RELIEF VALVE (HOT WATER)
33. 25 LITRE WATER STORAGE TANK
34. ANODE
35. NO RETURN VALVE

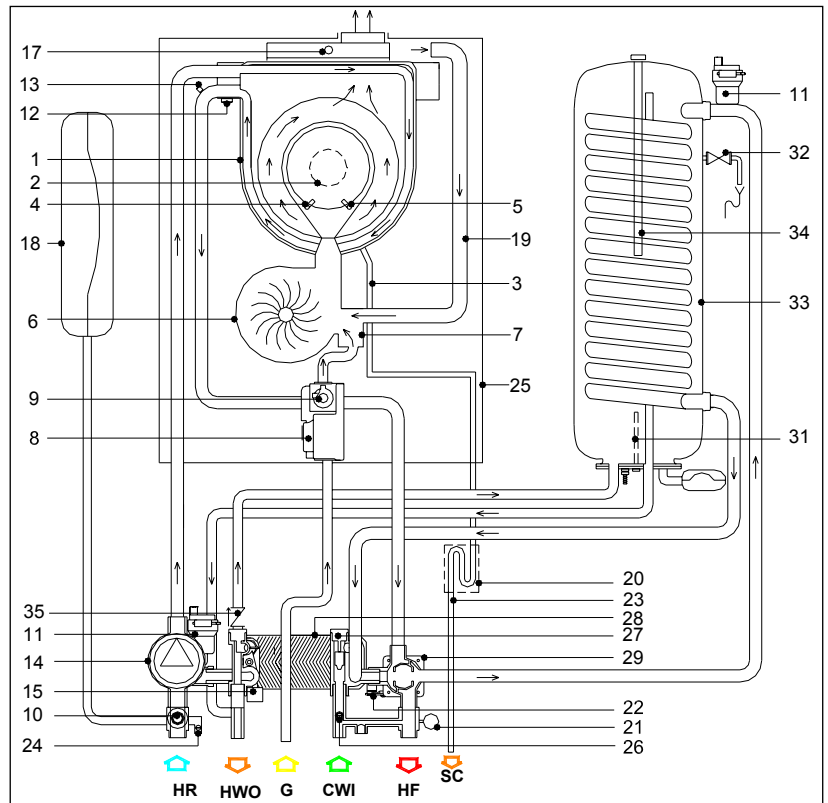

### LEGEND

HR HEATING RETURN	CWI COLD WATER INLET CONNECTION
HF HEATING FLOW	HWO HOT WATER OUTLET
G GAS	SC CONDENSATE DRAIN

## 2.5 Circulation pump head/flow graph

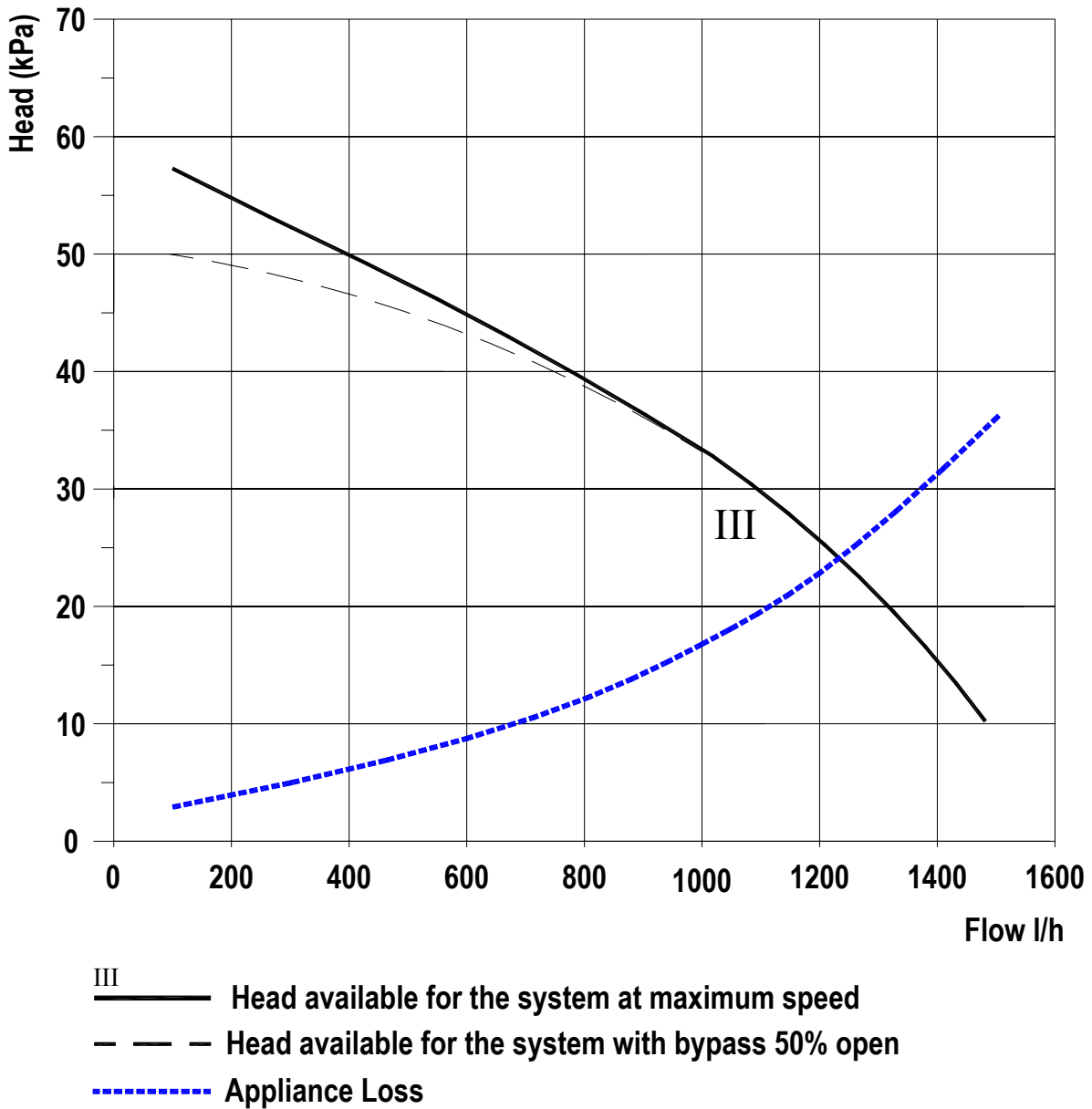

## 2.6 DIAGNOCODE® series SM 20015 Printed Circuit Board Technical characteristics Part Number 76655LA

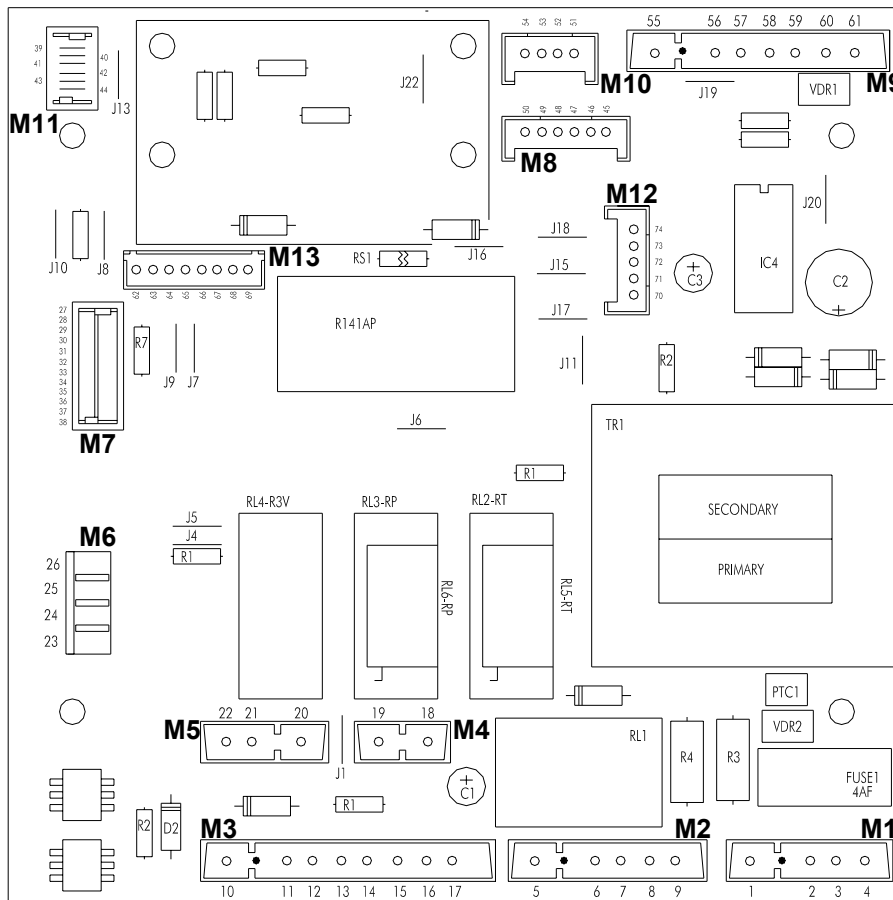

The new circuit boards greatly simplify the adjustment of the operating parameters of the entire system. In fact, it is now possible to adjust the following settings:

### Adjustments possible by service personnel only

- Standard / reduced temperature 30/80 – 25/40
- Water hammer prevention function
- Heating timer adjustable from 0 to 7.5 minutes standby Anti cycling device
- Central heating Pump overrun
- D.H.W Pump overrun
- Minimum gas pressure
- Maximum heating Load

### User settings

- On/Off
- Heating temperature 30-80 °C – 25-40°C (reduced)
- D.H.W temperature 35-60 °C
- Summer/winter/heating only
- Lock-out
- Normal water pressure
- Water deficiency indicator
- Temperature display

## 2.7 Control panel

### LEGEND

1. ON/OFF SWITCH
2. HEATING TEMPERATURE CONTROL KNOB
3. D.H.W TEMPERATURE CONTROL KNOB (*only for model RKR 25*).
4. OUTSIDE TEMPERATURE DISPLAY BUTTON (ONLY WITH OPTIONAL OUTDOOR SENSOR FITTED)
5. SERVICE BUTTON.
6. SUMMER, WINTER OR SUMMER/WINTER SELECTION BUTTON.
7. TERMINAL BOARD FOR EXTERNAL WIRING.
8. D.H.W FUNCTION INDICATOR (THE BOILER IS IN SUMMER OR SUMMER/WINTER MODE ) (*only for model RKR 25*)
  - FIXED LIGHT – Hot water mode is selected
  - FLASHING LIGHT - THERE IS A CURRENT DEMAND FOR HOT WATER
9. CENTRAL HEATING FUNCTION INDICATOR (THE BOILER IS IN WINTER OR SUMMER/WINTER MODE )
  - FIXED LIGHT – Heating mode has been selected
  - FLASHING LIGHT - There is a current demand for heating
10. ERROR WARNING LIGHT. THE APPROPRIATE ERROR CODE FLASHES ON THE DISPLAY (13)
11. LED INDICATING SYSTEM WATER PRESSURE AT 1.5 BAR
12. LED INDICATING INSUFFICIENT WATER IN THE SYSTEM
13. TEMPERATURE AND ERROR CODE DISPLAY

### ERROR CODES:

1. IONISATION LOCKOUT
2. SAFETY THERMOSTAT TRIPPED
3. EXHAUST THERMOSTAT TRIPPED ( *NOT-APPLICABLE* )
4. LOW WATER PRESSURE ALARM
5. HEATING SENSOR MALFUNCTION
6. D.H.W SENSOR MALFUNCTION (*ONLY FOR MODEL RKR 25*)
12. BOILER D.H.W SENSOR MALFUNCTION ( *NOT-APPLICABLE* )
14. AIR PRESSURE SWITCH MALFUNCTION ( *NOT-APPLICABLE* )
22. PARAMETER PROGRAMMING RESET REQUEST

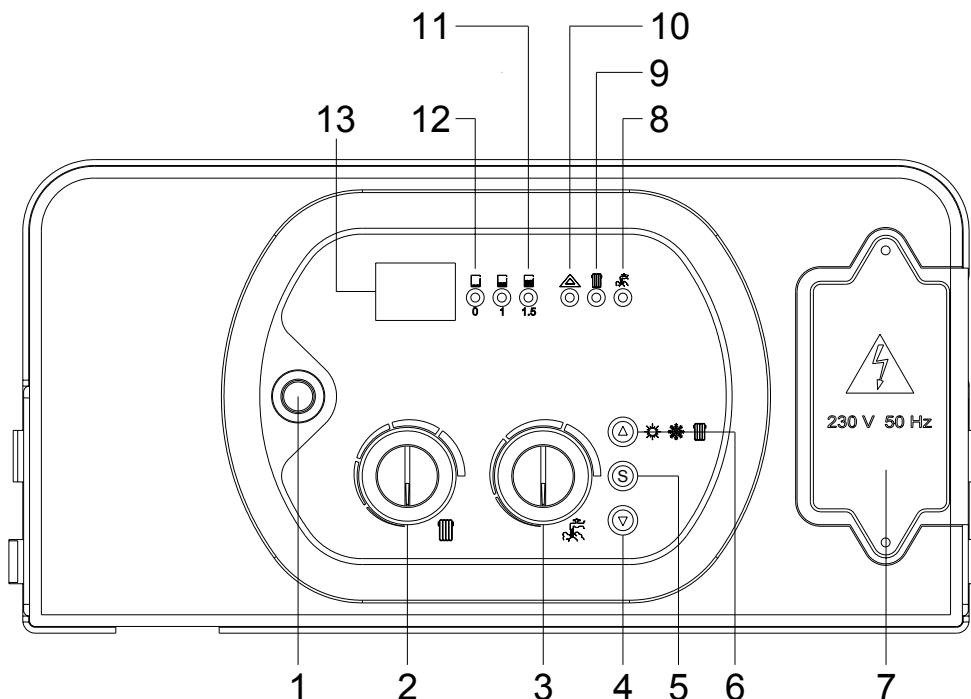

## 3. INSTALLING THE APPLIANCE

### 3.1 Reference standard

The following list is the full lists of codes of practice and British Standards That engineers should work to in the UK.

It is law in the UK that a competent person installs all gas-burning appliances. Please ensure that the installer is a class of person approved for the time being by the Health and Safety Executive for the purpose of carrying out this work. An approved engineer should be registered to an approved scheme i.e. CORGI 01256-372400.

All works should be carried out in accordance with the following,

Health & Safety at Work Act 1974

Gas Safety & Use Regulations 1998

All relevant Building Regulations as detailed by the office of the Deputy

Prime Minister, Parts A-structure, B-safety in fire, F-ventilation, G3-Hot water storage,

J-Heat producing Appliances, L- Fuel conservation (amended)

Building Standards Scotland

The Water Supply Regulations 1999

The Water Bylaws Scotland 2000

The Electricity at work regulations 1999

The installations should be carried out in accordance with the following British Standards Codes of Practice

BS 5440:Part1 2000 – Flues

BS 5440:Part2 2000 – Air Supply

BS 6700: 1987 – Specification for installation of cold water supplies for domestic purposes (1<sup>st</sup>, 2<sup>nd</sup> and 3<sup>rd</sup> family gases)

BS 5449: 1990 Forced circulation hot water systems

BS 5446: 2000 Specification for installation of hot water supplies for domestic purposes (1<sup>st</sup>, 2<sup>nd</sup> and 3<sup>rd</sup> family gases)

BS6798: 2000 Specification for installation of gas-fired boilers of rated input not exceeding 70 kW net

BS6891: Specification for installation of low pressure gas pipe work of up to 28 mm (R1) in domestic premises (2<sup>nd</sup> family gas)

BS7593: 1992 Code of practice for treatment of water in domestic hot water central heating systems

BS7671: 2001 IEE wiring regulations.

This appliance meets the requirements of IPX4D rating for electrical appliances.

Failure to install a gas appliance correctly and in accordance with the above norms could lead to prosecution. It is in the interest of the installer and safety that the law is complied with.

The manufacturers instructions form an integral part of the installation and should be left with the appliance but do not over ride in anyway statutory obligations.

### 3.2 Unpacking

- The materials (cardboard) used for packing the appliance are fully recyclable.
- It is recommended that the packing material is only removed prior to installing the boiler. The manufacturer will not be held responsible for damage caused by incorrect storage of the product.
- Packing materials (plastic bags, polystyrene, nails, etc.) must not be left within reach of children, in that these items represent a potential hazard.

**A.** Place the packed appliance on the floor (fig. 1) making sure that the "up" arrow is facing down. Remove the staples and open out the four flaps of the box.

**B.** Rotate the boiler 90° while manually supporting it from underneath

**C.** Lift the box and remove the protections. Lift the boiler by grasping the rear part and proceed with the installation.

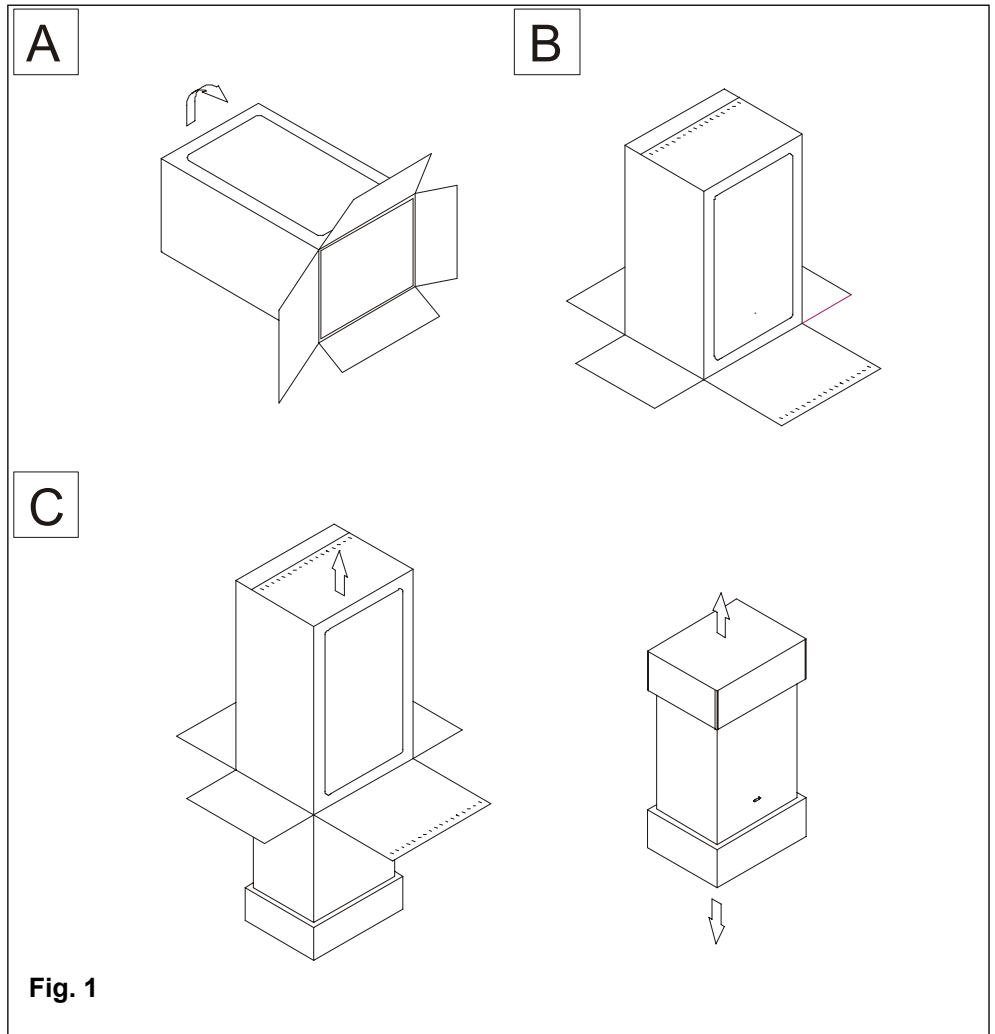

### STORAGE & HANDLING

Please note that prior to installation the Radiant boilers should be stored in the horizontal position with no more than three boilers to a stack; Ensure that the boilers are stored in dry conditions and be aware that the carton is a tow-man lift;

Please check that this boiler has been supplied with an unvented inlet kit and flue system



### 3.3 Installing the boiler

- The appliance must be installed exclusively on a flat vertical wall capable of supporting its weight.
- When mounting the boiler on the wall, make absolutely sure that the boiler is fitted perfectly level. If the boiler is not level, the condensate will not flow correctly through the drainpipe but will instead accumulate inside the main exchanger and stop it from working.

In order to allow access to the interior of the boiler for maintenance purposes, it is important that the minimum distances indicated in figure 1 are respected. To make the installation easier, the boiler is supplied with a template to enable the pipe connections to be positioned prior to fixing the appliance to the wall.

To install the boiler, proceed as follows (see fig. 2):

- a. Use a spirit level (of not less than 25 mm long) to mark a horizontal line on the wall where the boiler is to be fitted.
- b. Position the top of the template along the line drawn with the level, respecting the distances indicated. Then mark the centres of the positions of the two wall-plugs or anchors. Finally, mark the positions of the water and gas pipes.
- c. Remove the template and install the domestic hot and cold water pipes, the gas supply pipe and the central heating pipes using the fittings supplied with the boiler.
- d. Please ensure that connections made to the storage cylinder pressure and temperature relief valve is solely used for this purpose and not shared with any other discharge or inlet pipe.
- e. Fix the boiler to the wall using the wall plugs or bracket and connect the pipes.

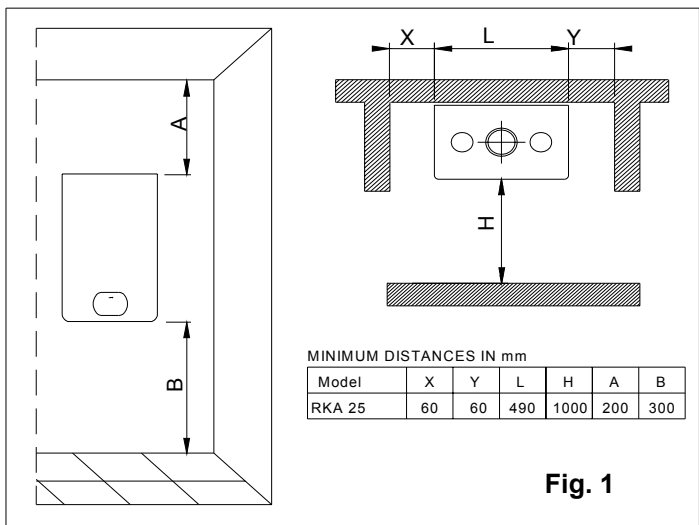

Fig. 1

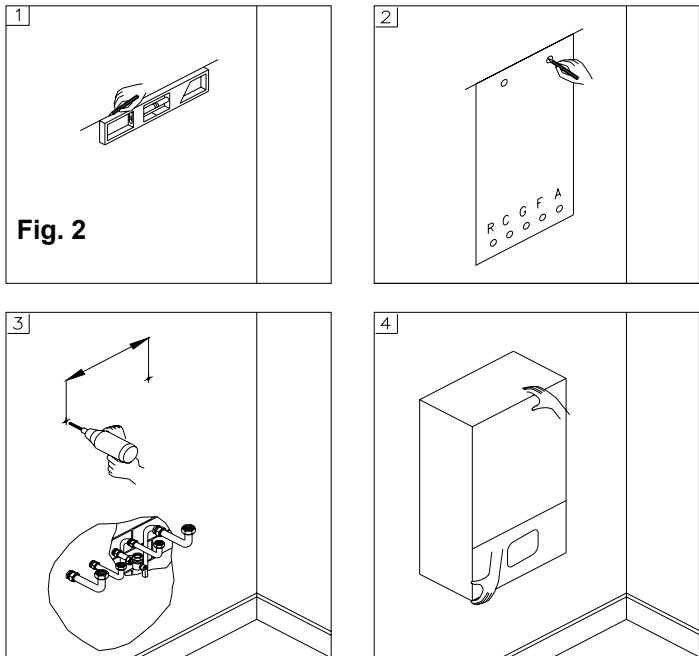

Fig. 2

### 3.4 Water connections

**⚠** In order to safeguard the heat exchanger and circulation pump, it is recommended that the system is hot-flushed to remove any impurities (especially oil and grease) from the pipes and radiators.

**⚠** Please ensure that all discharge and safety pipes are connected and terminated in line with page 17 of this manual

**⚠** Make sure that the domestic water and central heating pipes are not used to earth the electrical system. The pipes are totally unsuitable for this purpose.

**⚠** Isolating Valves must be installed on the heating and D.H.W circuits. This will facilitate all maintenance and service operations where the boiler needs to be drained.

■ To prevent vibration and noise coming from the system, do not use pipes of reduced diameter, short radius elbows or severe reductions in the cross sections of the water passages.

■ The increase in temperature of the hot water storage units causes a consequent increase in volume of the water contained in them. In order to compensate for this increase in volume, the appliance is fitted with an expansion vessel specifically for the domestic hot water system.

In order to guarantee the reliability of the boiler and prevent permanent damage in areas with high water inlet pressure too, a 3.5 bar pressure reducing valve should be fitted.

■ In order to prevent scaling and eventual damage to the D.H.W heat exchanger, the mains water supply must not have a hardness rating of more than 25 °F. It is nevertheless advisable to check the properties of the water supply and install the appropriate treatment devices where necessary.

**The cold water supply pressure at the inlet to the boiler should be between 0.5 and 3.5bar**

The frequency of the heat exchanger coil cleaning depends on the hardness of the mains water supply and the presence of residual solids or impurities, which are often present in the case of a new installation. If the characteristics of the mains water supply are such that require it to be treated, then the appropriate treatment devices must be installed, while in the case of residues, an in-line filter should be sufficient.

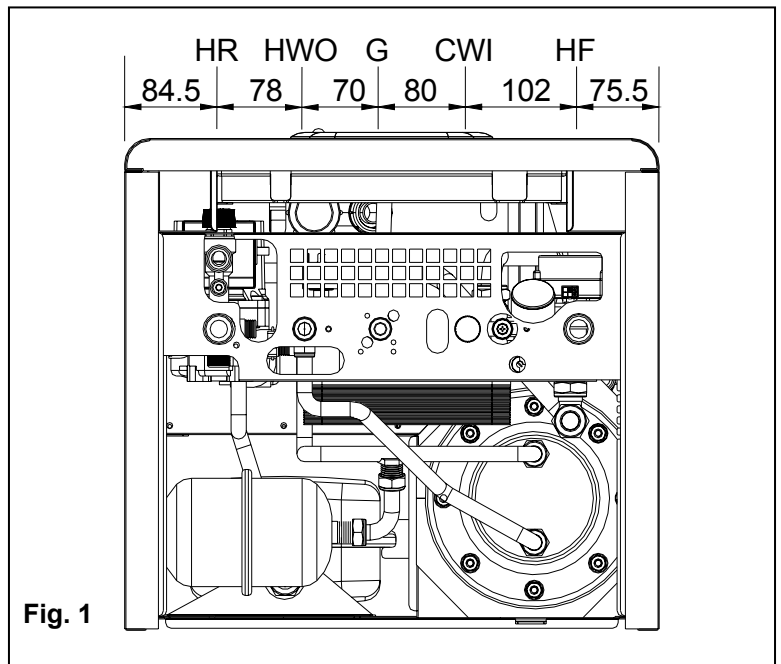

Fig. 1

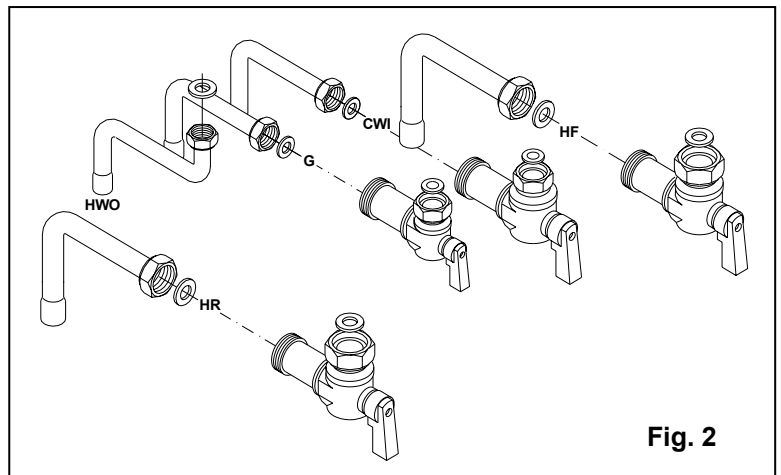

Fig. 2

### 3.5 Central heating circuit

The boiler is designed for use in a sealed central heating system in accordance with the requirements of BS 5449 and BS 6798. The system should be designed to operate with flow temperatures of up to 82°C. When designing the system, the pump head, expansion vessel size, mean radiator temperature, etc. must all be taken into account. Refer to the pump performance table for guidelines.

System volume -The expansion vessel incorporated into the boiler is suitable for a sealed heating system  
 The boiler is supplied with the following components built in:-

**Pressure relief valve** -complying with BS 6759 and set to operate at 3 bars. The outlet connection of the boiler safety valve must terminate to atmosphere in accordance with current regulations. The manufacturer will not be held responsible for flooding caused by the operation of the safety valve in the case of system overpressure..

**Pressure gauge** -To indicates the system pressure to be maintained.

**Expansion vessel.** Conforming to BS 4814 with a capacity of 10 litres.

**By-pass** -The boiler incorporates a by-pass, however where all radiators are fitted with thermostatic radiator valves it is recommended an automatic system by-pass is fitted.

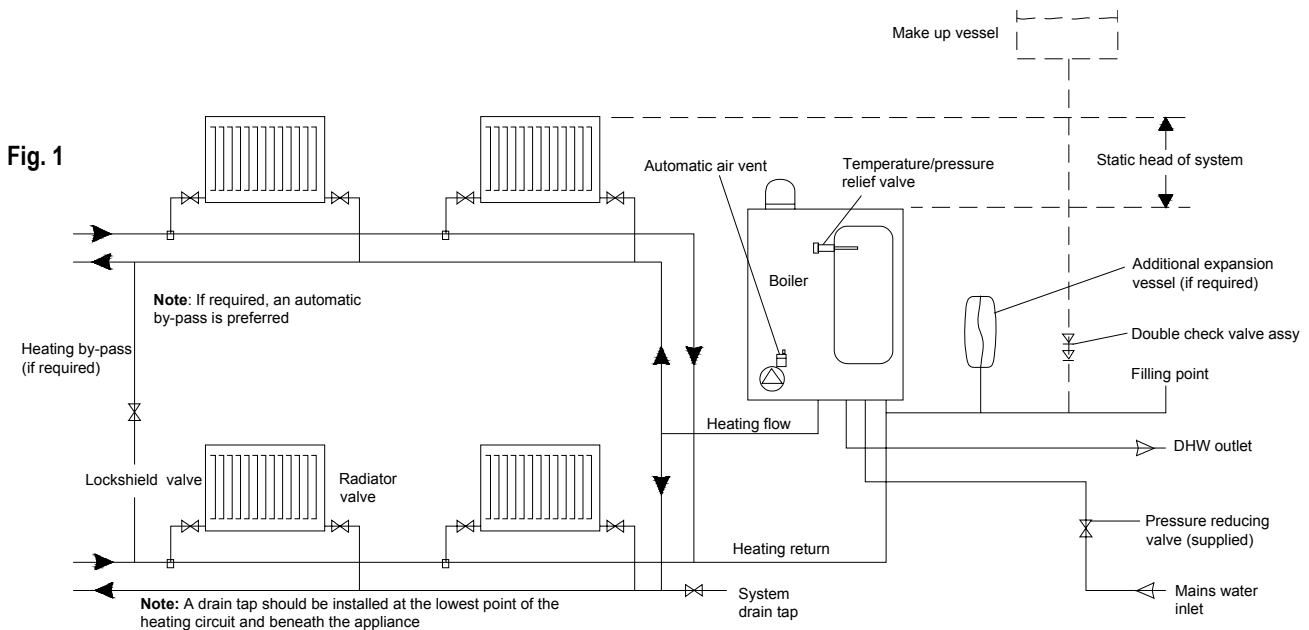

#### Filling the central heating system - figs. 2-3

The system design pressure (cold) should be set to 1.5 bar. This pressure is equivalent to a static head of 15.4 metres of water.

Provision should be made to replace water lost from the system. This can be by manual or automatic means. as shown in Figs. 2 and 3. The position for connecting an automatic make-up vessel is indicated in Fig. 1. A double check valve assembly must be used. as shown in Fig. 3.

Filling of the system must be carried out in a manner approved by the local Water Undertaking. Where allowed the system may be filled via a temporary connection as shown in Fig. 2. After filling, always disconnect the flexible hose of the filling loop.

All fittings used in the system must be able to withstand pressures up to 3 bar.

Drain taps (to BS 2879) must be used to allow the system to be completely drained.

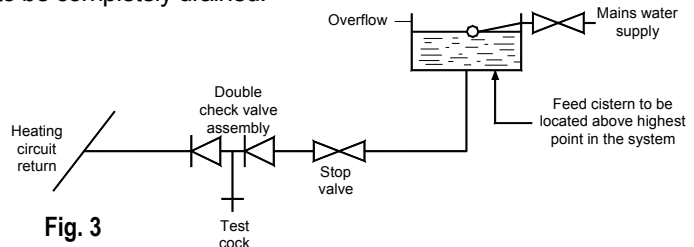
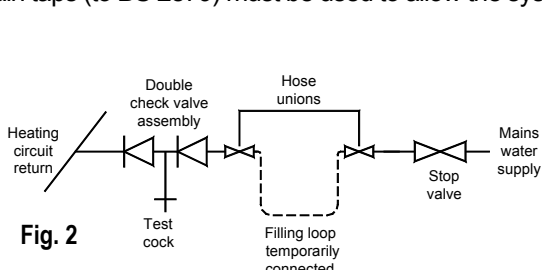

**In order to prevent scaling or deposits in the primary heat exchanger, the mains supply water to the heating circuit must be treated according to the requirements of standard.**

This treatment is indispensable in the case where the circuit is frequently topped-up or when the system is often either partially or fully drained.

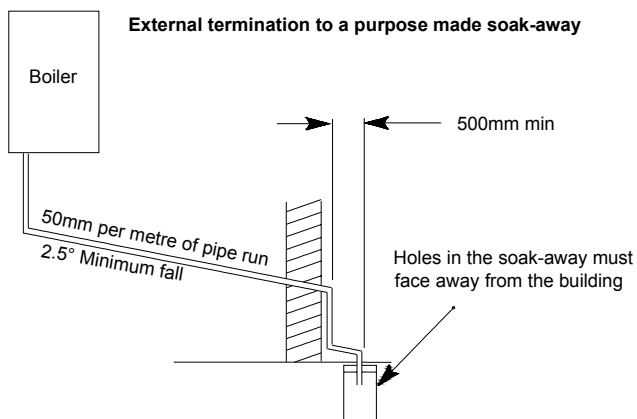
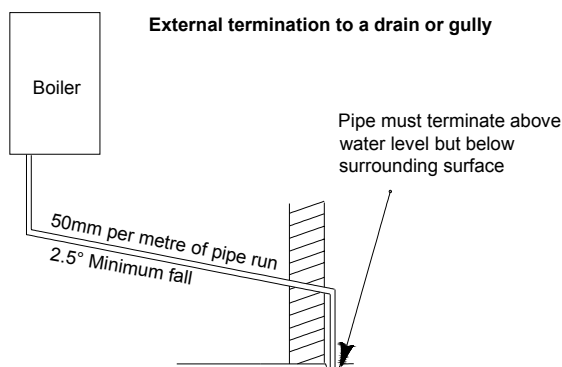
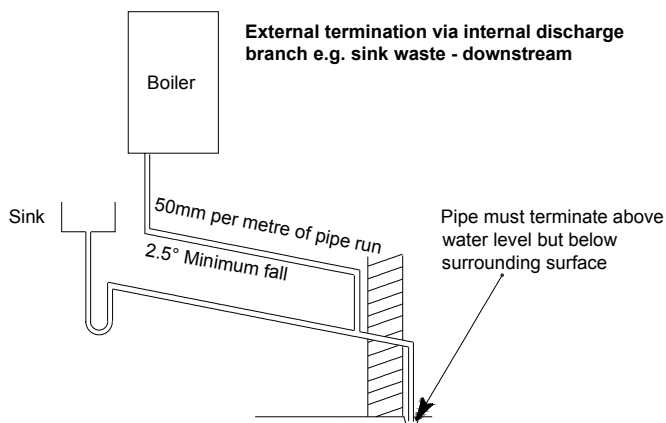
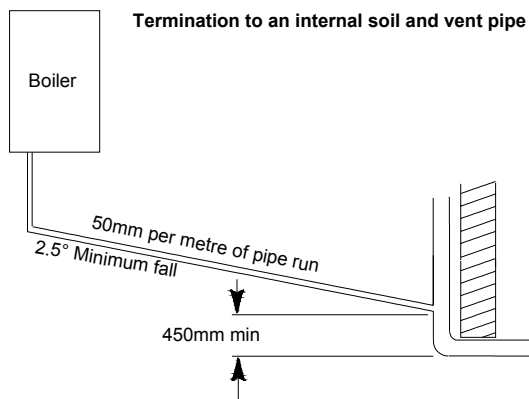

### 3.6 Condensate drain

FAILURE TO INSTALL THE CONDENSATE DISCHARGE PIPEWORK CORRECTLY WILL AFFECT THE RELIABLE OPERATION OF THE BOILER. The condensate discharge pipe MUST NOT RISE at any point along its length. There MUST be a fall of AT LEAST 2.5° (50mm per metre) along the entire run.

1. The condensate outlet terminates in 22 mm nut and seal for the connection of 22 mm (3/4 in) plastic overflow pipe which should generally discharge internally into the household drainage system. If this is not possible, discharge into an outside drain is acceptable.
2. Ensure the discharge of condensate complies with any national or local regulations in force.
- BS 6798:2000 & Part H I of the Building Regulations give further guidance.**
3. The discharge pipe should be run in a proprietary drain pipe material e.g. PVC, PVC-U, ABS, PVC-C or PP.
4. Metal pipe work is NOT suitable for use in condensate discharge systems.
5. The pipe should be a minimum of 21.5 mm diameter and must be supported using suitably spaced clips to prevent sagging.
6. Any pipe fitted externally must not exceed 3 metres.
- 7 Any condensate discharge pipe work external to the building (or in an unheated part of it e.g. garage) must be insulated to protect against frost. It is also recommended that the pipe diameter is increased to 32mm.
8. If the boiler is fitted in an unheated location the entire condensate discharge pipe should be treated as an external run.
9. In all cases discharge pipe must be installed to aid disposal of the condensate. To reduce the risk of condensate being trapped, as few bends and fittings as possible should be used.
10. When discharging condensate into a soil stack or waste pipe the effects of existing plumbing must be considered. If soil pipes or waste pipes are subjected to internal pressure fluctuations when WC's are flushed or sinks emptied then back-pressure may force water out of the boiler trap and cause appliance lockout. Examples are shown of the following methods of termination:-
  - i) to an internal soil & vent pipe
  - ii) via an internal discharge branch (e.g. sink waste)
  - iii) to a drain or gully
  - iv) to a purpose made soak away

### 3.7 Discharge piping

The discharge pipework from the tundish:

1. Shall fall continuously through its length.
2. Shall be of metal construction
3. Shall not be fitted with any valves or taps.
4. Shall discharge to a safe visible position, e.g. onto the surface of an external wall or into a gully.
5. Shall have a minimum of 300 mm straight pipework directly from the tundish.

**Note:** Where persons may come into contact with discharges, a wire or similar guard must be positioned to prevent contact whilst maintaining visibility.

Refer to Fig 1 for suggested methods of terminating the discharge pipe safely.

Where a single pipe serves a number of discharge, such as in blocks of flats, the number served should be limited to no more than 6 systems so that any installation can be traced reasonably easily. The single common discharge pipe should be at least one pipe size larger than the largest individual discharge pipe to be connected.

If the system is installed where discharge from safety devices may not be apparent, i.e. in dwellings occupied by blind, infirm or disabled people, consideration should be given to the installation of an electronically operated device to warn when discharge takes place.

#### HIGH LEVEL DISCHARGE TERMINATION

At high level, discharge onto a roof is acceptable providing the roof is capable of withstanding high temperatures and there is a distance of 3 metres from any plastic guttering systems that would collect such discharge.

**Note:** The discharge will consist of scalding water and steam. Asphalt, roofing felt and non-metallic rainwater goods may be damaged by such discharge.

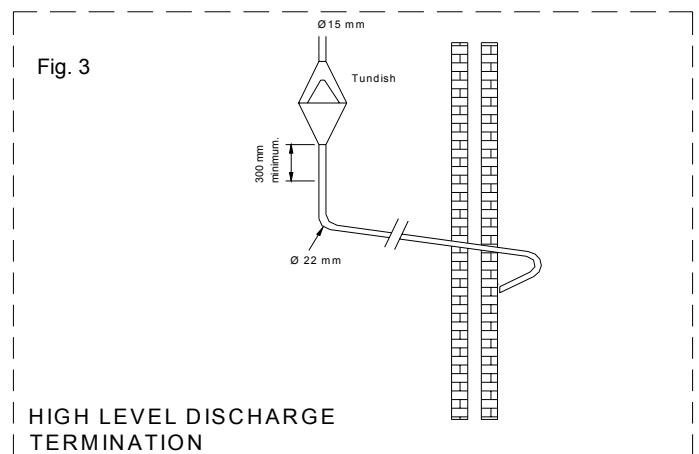
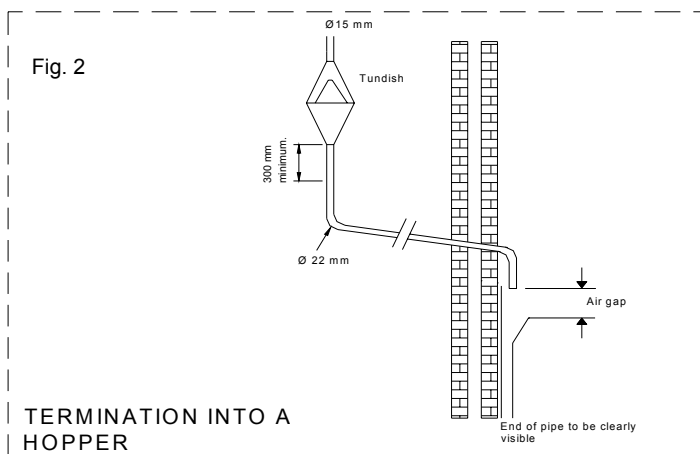
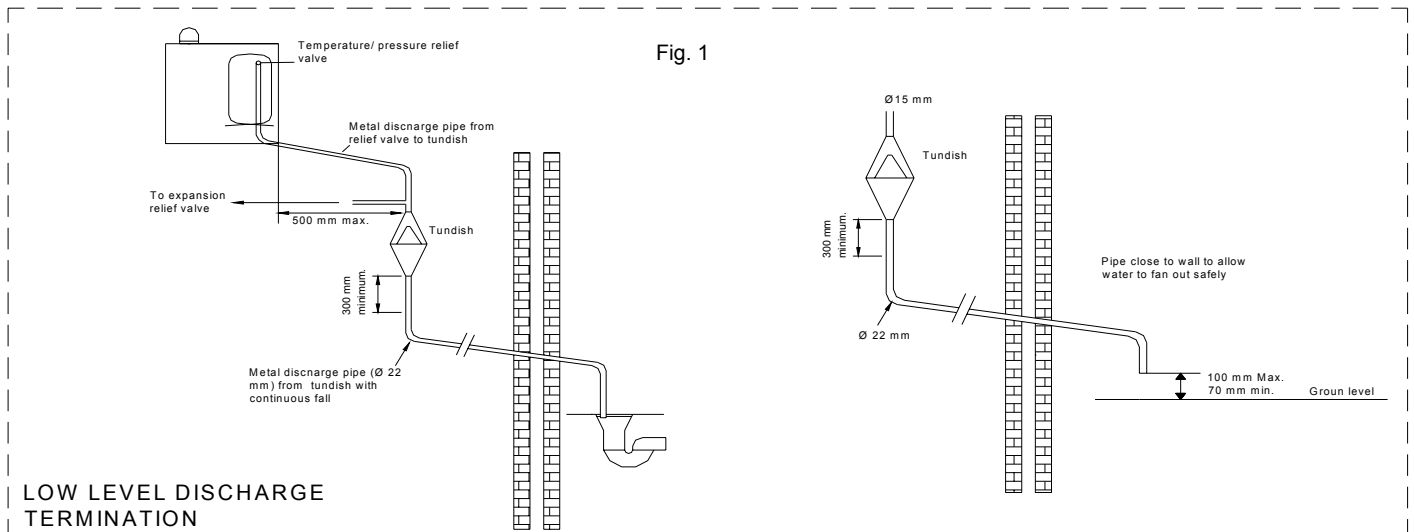

### 3.8 D.H.W. circulating loop

- a. unscrew cap **A** on the top of cylinder.
- b. Insert the copper pipe **B**, supplied by the manufacturer, into the  $\frac{1}{2}$ " connection and then connect the loop pipe **C**.
- c. if the system requires an additional expansion vessel for the D.H.W. circuit, insert a 'T' between the loop pipe and the  $\frac{1}{2}$ " connection.

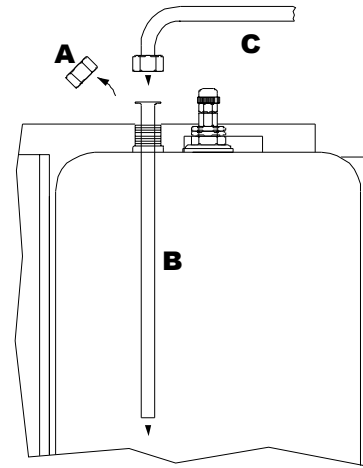
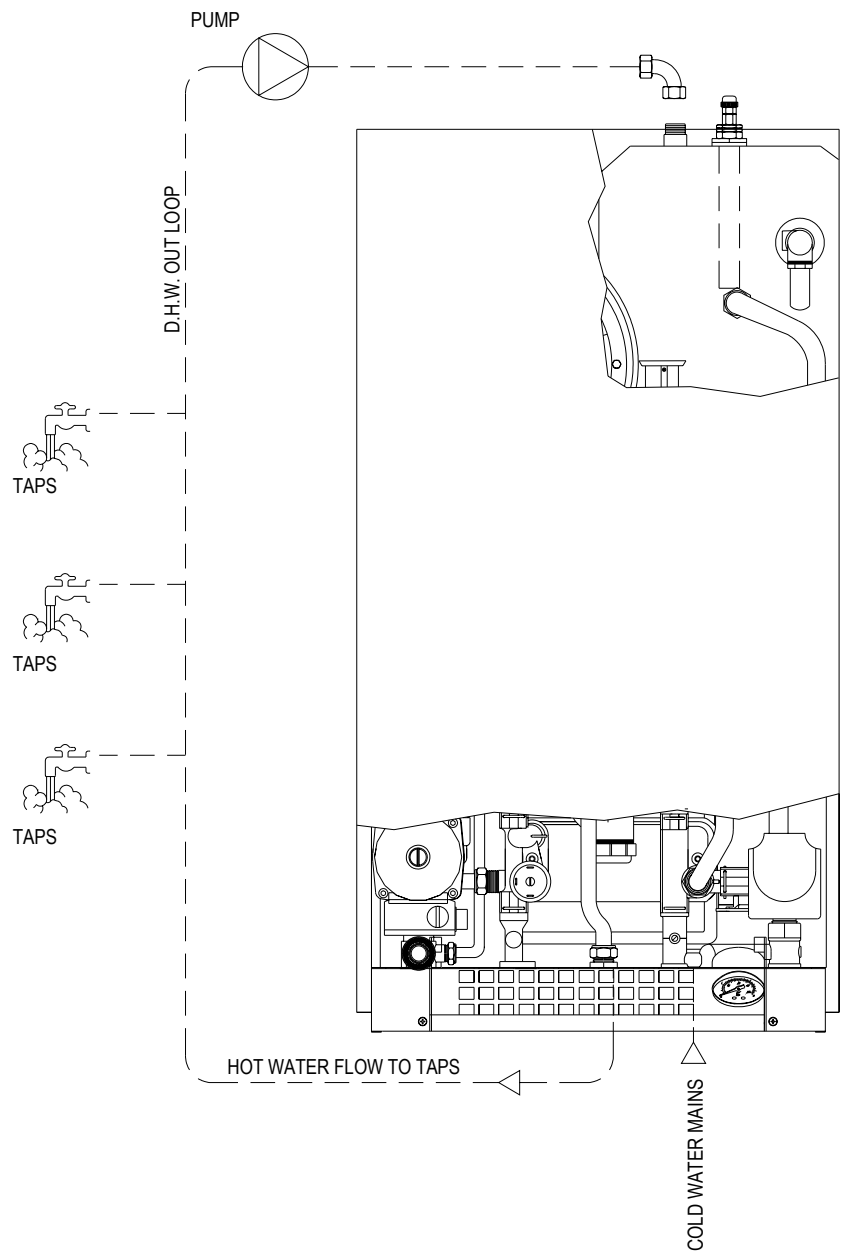

Fig. 1



### 3.9 Gas connection

**⚠** The connection to the gas supply must be carried out by professionally qualified personnel, registered in accordance with current legislation and CORGI.

**⚠** When connecting the boiler to the gas supply pipe, only use appropriate gas fittings in accordance with the Gas Safety and Use Regulations..

**Before installing the boiler, check the following:**

- The pipe work must have a section appropriate for the flow rates requested and the pipe lengths installed, and must be fitted with all the safety and control devices provided for by current standards.
- The gas supply line must be a minimum of a 22mm diameter pipe with an uninterrupted supply from meter to boiler and comply with current standards and regulations.
- **Check the internal and external seals of the gas supply system.**
- A gas shut-off valve must be installed upstream of the appliance
- Before starting up the boiler, make sure that the type of gas corresponds to that for which the appliance has been set-up (see gas type label inside the boiler).
- The gas supply pressure must be between the values reported on the rating plate inside the appliance.
- Prior to installation, it is good practice to ensure that there are no machining residues on the gas supply pipe.
- Conversion of the appliance from natural gas to LPG or vice versa must be carried out by qualified personnel.

### 3.10 Electrical connections

**⚠** The connection to the mains power supply must be carried out by professionally qualified personnel, registered in accordance with current legislation and authorised by Radiant Bruciatori.

**⚠** Always check to make sure that the appliance has an efficient earth system. This requirement is only satisfied if it has been properly connected to an efficient earth system installed in accordance with the requirements of current safety standards (Standard CEI 64-8 Electrical Installations). This basic safety measure must be checked and verified.

In case of doubt, have the electrical system checked by a qualified electrician. The manufacturer will not be held liable for any damage or injury caused as a result of an inefficient or inexistent earth system.

- **The boiler is manufactured to European standard X4D for Electrical Protection.**
- The boiler functions with an alternating current of 230 V and 50 Hz and has maximum power absorption of 180 W. The boiler should be protected by a 3 amp fuse. The connection to the mains electricity supply must be via a single-pole switch, with at least 3 millimetres gap between open contacts, mounted upstream of the appliance. Make sure that the positions of the live and neutral wires correspond to the wiring diagram.
- Ensure the domestic power supply is checked by a qualified electrician to ensure that it can support the maximum power absorption of the appliance, as indicated on the rating plate. In particular, make sure that the cable sizes are adequate for the power absorbed by the appliance.
- The power supply cable must not be replaced by the user. If the cable is damaged in any way, switch off the appliance and have the cable replaced by a suitably qualified electrician.
- When replacing the power supply cable, only use cables of the same characteristics (HO5 VV-F 3x1) with maximum external Ø 8 mm;

**When using an electrical appliance, a few fundamental rules must be observed:**

- Do not touch the appliance with damp or wet parts of the body or when barefoot.
- Do not pull on the electric wires.
- Do not leave the appliance exposed to atmospheric elements (rain, sun, etc,) unless these conditions have been expressly provided for.
- Do not allow the appliance to be used by children or anyone unfamiliar with its operation.

▪ **Electric power supply**

**Connect the power supply to the terminal board inside the control panel as follows:**

- a. Switch off the power supply at the main switch.
- b. Remove the front panel of the boiler.
- c. Slacken the screws and remove plate A (see fig. 1).
- d. With the plate removed, connect the wires to the terminal board B as follows:
  - Connect the earth wire (normally coloured green/yellow) to the terminal marked with the earth symbol “ $\perp$ ”.
  - Connect the neutral wire (normally coloured blue) to the terminal marked with the letter “N”.
  - Connect the live wire (normally coloured brown) to the terminal marked with the letter “L”.
- Terminals identified by the letters: Ta  $\Rightarrow$  Room thermostat  
Se  $\Rightarrow$  Outdoor sensor

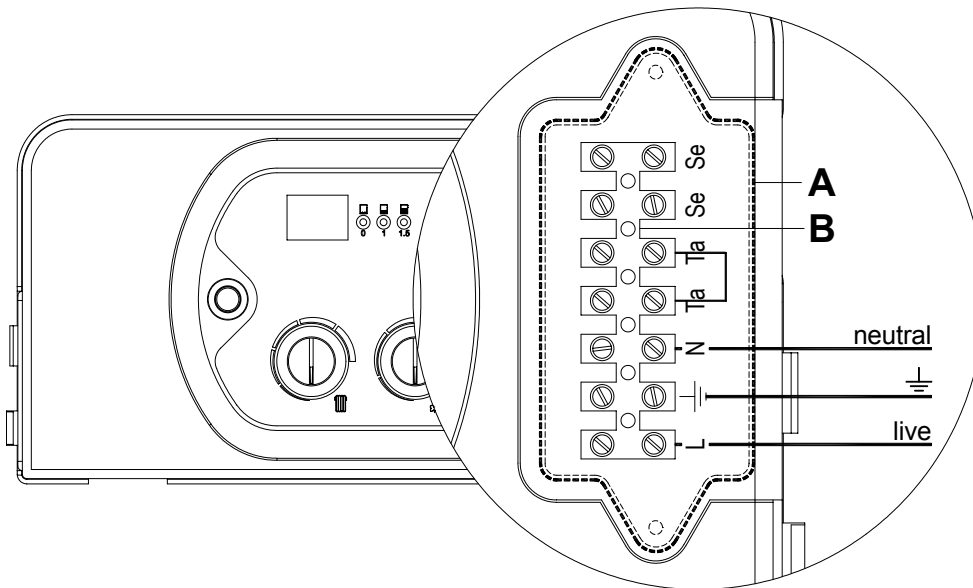

**Fig. 1**

When the wires have been connected, replace plate “A” and then the front panel.

**3.11 Connecting the room thermostat and outdoor sensor**

please include the external temperature sensor part number.

**Connect the wires to the terminal board inside the instrument panel as follows**  
(Example of WEEK digital room thermostat/time):

- a. Switch off the power supply at the main switch.
- b. Remove the front panel of the boiler.
- c. Slacken the screws and remove plate A (see fig. 2).
- d. Remove jumper TA-TA from the terminal board.
- e. Connect the thermostat/timer wires.

When the wires have been connected, replace plate “A” and then the front panel.

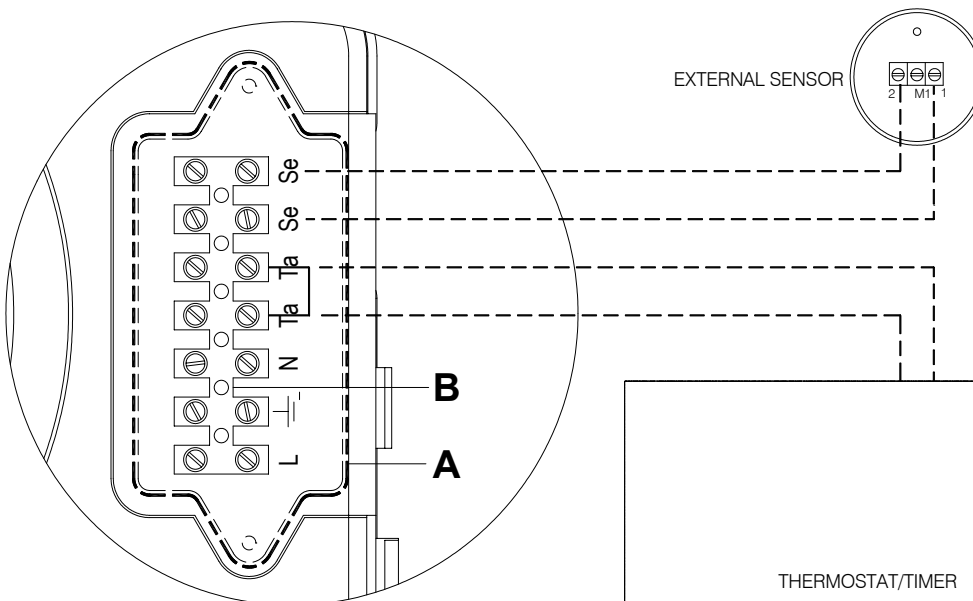

**Fig. 2**



### 3.12 Connecting the “Remoto” thermostat/timer

If the optional remote thermostat/timer has been purchased, this must be connected to the modulation board installed in the boiler control panel.

To access the modulation board, proceed as follows:

1. Switch off the power supply at the main switch.
2. Remove the front panel of the boiler.
3. Bend the two panel support brackets outwards slightly and at the same time rotate the panel downwards.
4. Unscrew the four fixing screws and remove the cover.
5. Fit the remote control interface on the modulation circuit board by pressing it in position, making sure that the four lugs are inserted in the corresponding holes in the board (holes A and B).

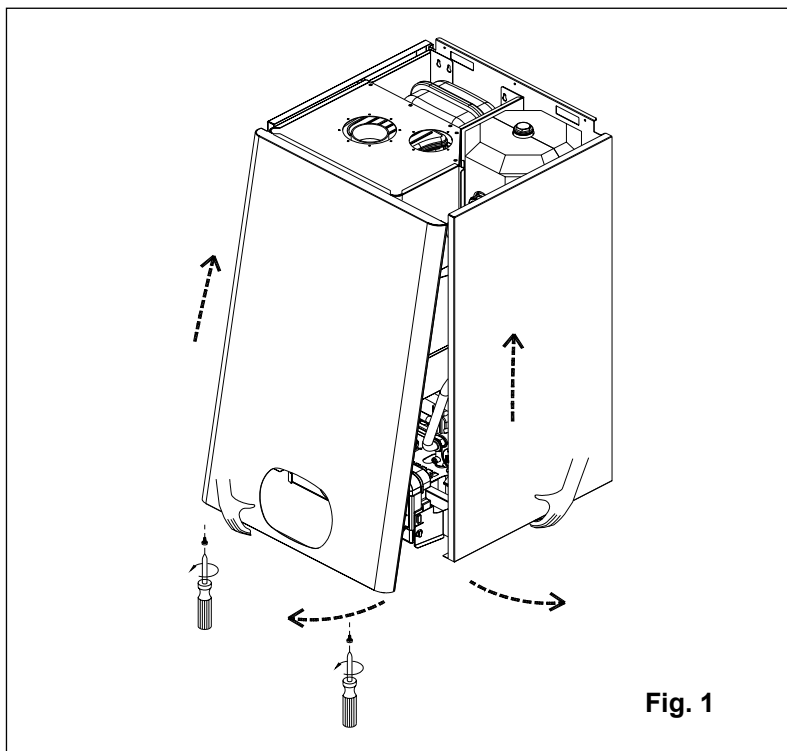

Fig. 1

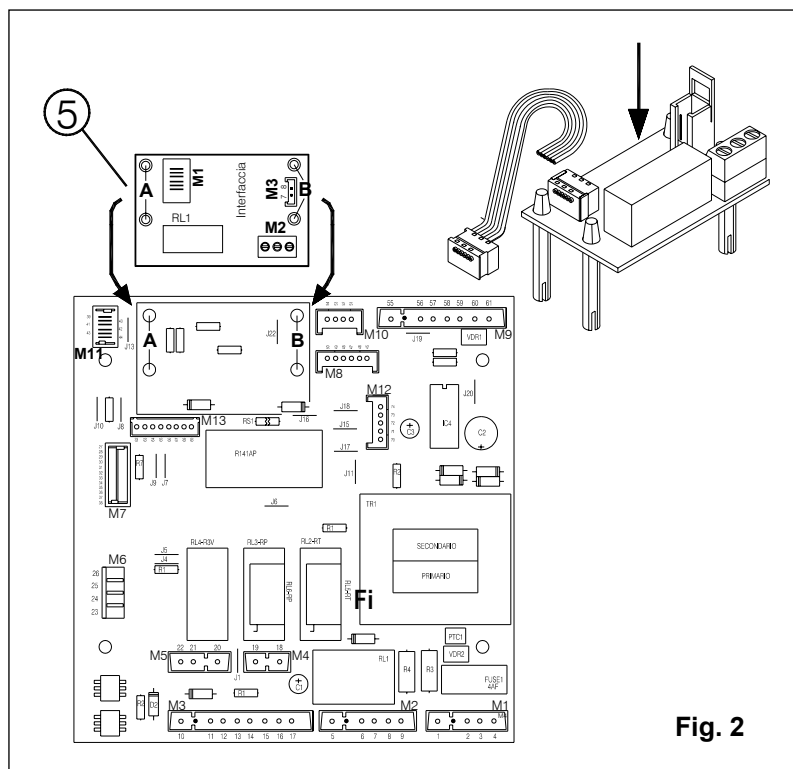

Fig. 2

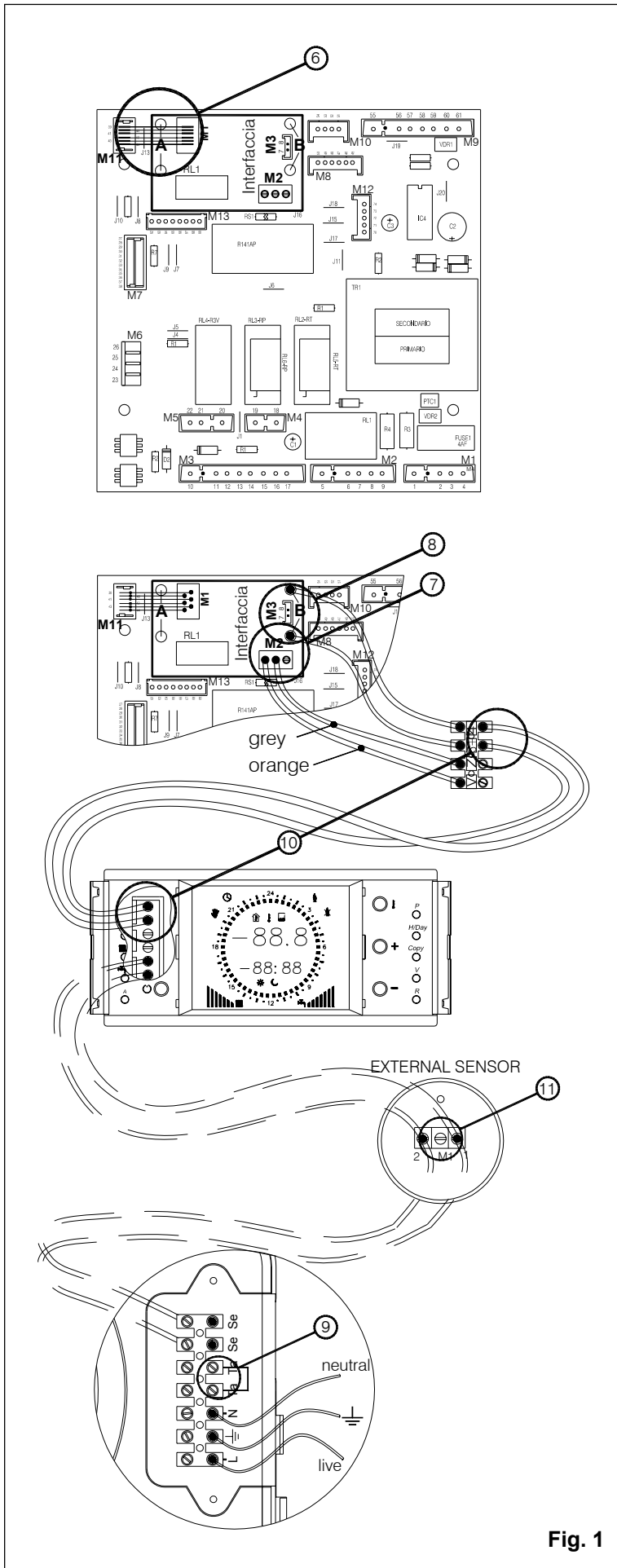

Fig. 1

6. Connect plug M1 to the interface board and plug M11 to the modulation board (fig. 1).
7. Connect the grey and orange wires to plug M2 of the interface board and to the terminal board.
8. Connect the wires of plug M3 on the interface board to the terminal board.
9. Remove jumper TA-TA and set the boiler to SUMMER mode.
10. Connect the remote control to the terminal board using a 2 x 0.5 mm<sup>2</sup> minimum section cable of length not exceeding 50 metres. Remember to respect the polarities +/-.
11. Connect the outdoor sensor. The connection can be made either to the remote control or to the terminals marked SE-SE on the terminal board.

**⚠ WARNING!** If the cable is wired to the remote control, it must be housed in a separate channel to the electrical wiring. If this is not possible, use a shielded cable.

## Regulating the Flow temperature in accordance with the outdoor temperature

The outdoor sensor can be connected either to the remote control or directly to circuit board SM 20015. The sensor can thus be managed in one of two ways:

- if the sensor is wired to the remote control, the climatic compensation curve is set by the remote itself (see remote control installation and operating manual).
- if the sensor is wired directly to the circuit board, the climatic compensation curve is set using the central heating control knob. As the knob (fig. 2) is rotated, the numbers corresponding to the curve shown in figure 1 are displayed.

The factors governing the correction is reported in figure 1.

The selection of the compensation curve is determined by the maximum delivery temperature  $T_m$  and the minimum outdoor temperature  $T_e$ .

**N.B.** The y-axis values of the delivery temperature  $T_m$  refer to standard 80-30 °C appliances or 40-25 °C floor-mounted appliances. The type of appliance can be programmed using parameter 3 (see 5.1 “Parameter programming”).

**EXTERNAL SENSOR**  
DELIVERY TEMPERATURE CORRECTION AS A FUNCTION OF OUTSIDE TEMPERATURE WITH RESPECT TO THE POSITION OF THE HEATING TEMPERATURE CONTROL SET BY THE USER

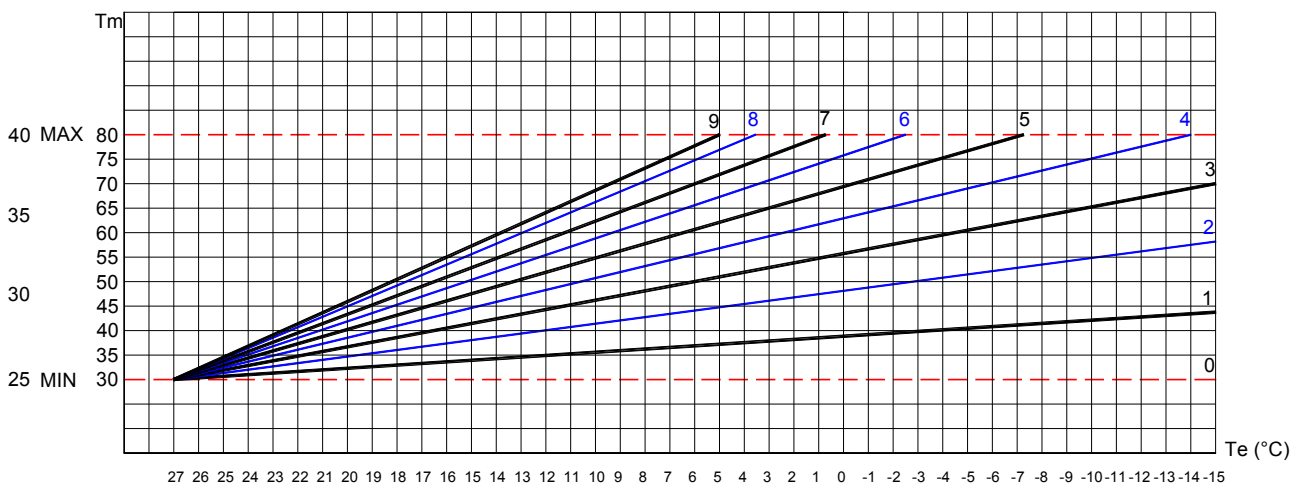

TM-MAX/MIN = delivery temperature range selected

$T_e$  = external temperature

$T_m$  = delivery temperature

**Fig. 1**

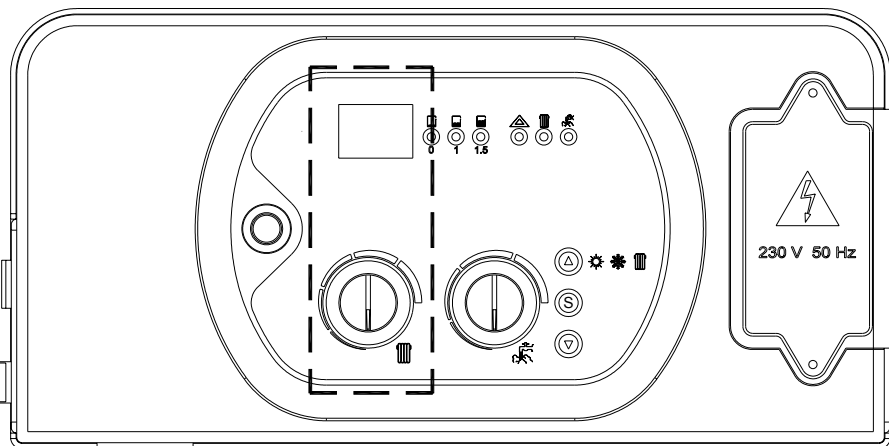

**Fig. 2**

### 3.13 Flue connections

**⚠ In order to ensure that the appliance functions correctly and efficiently, the flue connection between the boiler and the flue terminal must be made using original components specifically designed for condensing boilers.**

**⚠ Traditional flue components cannot be used for conveying exhaust fumes from condensing boilers, nor vice versa.**

- In order to make the choice of which flue to install easier, in addition to being drawn differently, the above-mentioned system is also differentiated in the flue catalogue and general price list by the insertion of the words "...in polypropylene..." .

- It is recommended that:

- For the exhaust discharge duct, the entire length of the flue slopes upwards towards the exterior in order to facilitate the flow of condensate back to the combustion chamber, which has been specifically designed to collect and drain the acidic condensate.

- For the air intake, the entire length of the duct slopes upwards towards the boiler to prevent the entry of rainwater, dust or foreign bodies into the pipe.

- In the case where a horizontal coaxial system is installed, the coaxial terminal must be positioned horizontally in that the exhaust duct has been specifically designed with the required slope (ø60) and the air intake (Ø100) has been suitably protected against the weather.

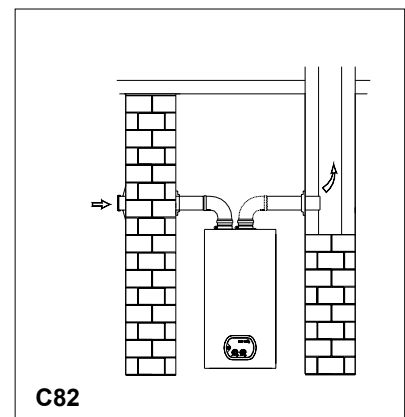
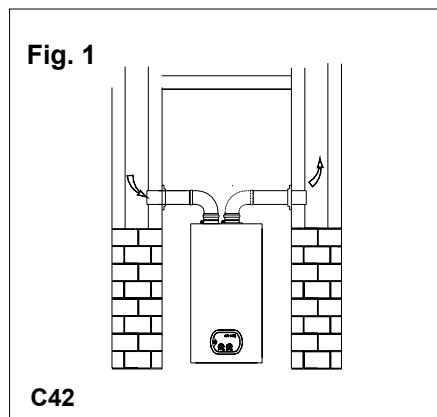
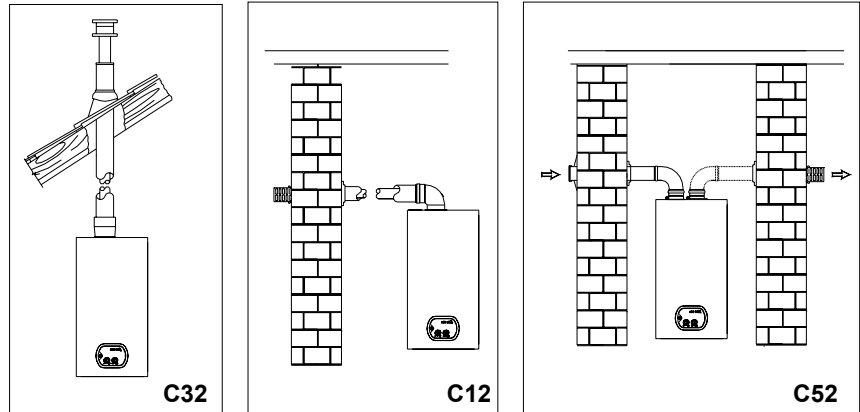

#### Flue Duct connection

Connect the flue to the chimney in accordance with the requirements of UNI-CIG 7129/01, 7131/99 and D.P.R. 412/03 and subsequent amendments.

- Do not allow the exhaust flue to protrude inside the chimney; instead terminate it before it reaches the flue duct.
- The exhaust flue must be perpendicular to the opposite wall of the flue duct (fig. 2).

#### Flue types

Exhaust flues for gas-fired appliances are classified at European level (fig. 1) according to the method used for drawing combustion air to and discharging exhaust fumes from the appliance. This classification applies to gas-fired appliances in general.

##### Type C appliances

An appliance in which the combustion circuit (air intake, combustion chamber, heat exchanger and fumes exhaust discharge) is sealed off from the room in which the appliance is installed, i.e. room-sealed.

The combustion air intake and the fumes exhaust discharge are connected directly to outside the room.

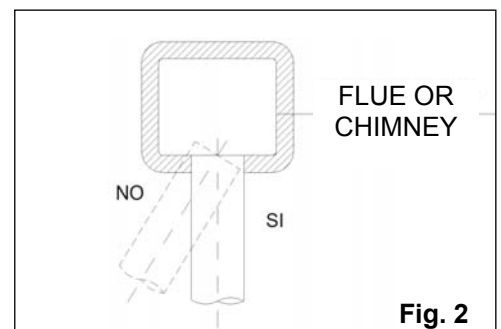

## Flue position

**IMPORTANT:** THE FLUE SYSTEM SHALL BE INSTALLED IN ACCORDANCE WITH THE RECOMMENDATIONS CONTAINED IN BS 5440:1.

The boiler **MUST** be installed so that the terminal is exposed to the external air.

It is important that the position of the terminal allows free passage of air across it at all times.

If the terminal discharges into a pathway or passageway check that combustion products will not cause nuisance and that the terminal will not obstruct the passageway.

In certain weather conditions a terminal may emit a plume of steam. Positions where this would cause a nuisance should be avoided.

**IMPORTANT REQUIREMENT:** The correct dimensional relationship between the terminal and any obstruction, openable window or ventilator as shown in Fig 1 It is **ESSENTIAL TO ENSURE**, in practice, that products of combustion discharging from the terminal cannot re-enter the building, or any other adjacent building, through ventilators, windows, doors, other sources of natural air infiltration, or forced ventilation/air conditioning systems. If this should occur, the appliance **MUST BE TURNED OFF IMMEDIATELY** and the local gas region consulted.

Where the lowest part of the terminal is fitted less than 2m (6.6ft) above a balcony, above ground, or above a flat roof to which people have access, the terminal **MUST** be protected by a purpose designed guard.

Where the terminal is fitted within 850mm (34in) of a plastic or painted gutter, or 450mm (18in) of painted eaves, an aluminium shield of at least 1000 mm (40in) long should be fitted to the underside of the gutter painted surface.

The air inlet/products outlet duct and the terminal of the boiler **MUST NOT** be closer than 25mm (1in) to combustible material.

## TERMINAL POSITION

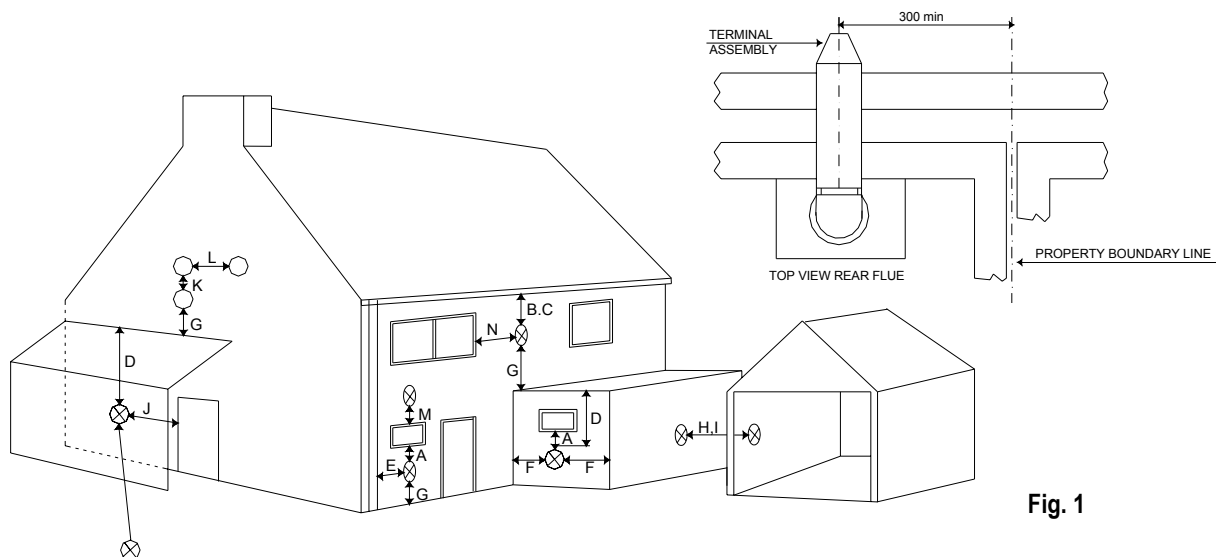

Fig. 1

<b>A</b>	Directly below an openable window, air vent or any other ventilation opening.	300 mm
<b>B</b>	Below gutter, drain pipes or soil pipes.	75 mm
<b>C</b>	Below eaves.	25 mm
<b>D</b>	Below balcony or carport roof.	25 mm
<b>E</b>	From vertical drain pipes or soil pipes.	25 mm
<b>F</b>	From internal or external corners.	25 mm
<b>G</b>	Above adjacent ground, roof or balcony level.	300 mm
<b>H</b>	From a surface facing the terminal.	600 mm
<b>I</b>	Facing the terminals.	1200 mm
<b>J</b>	From opening (door, window) in the carport into dwelling.	1200 mm
<b>K</b>	Vertically from a terminal on the same wall	1500 mm
<b>L</b>	Horizontally from a terminal on the same wall	300 mm
<b>M</b>	Above an opening, air brick, opening window etc.	300 mm
<b>N</b>	Horizontally to an opening, air brick, opening window etc.	300 mm

## ■ Chimneys – UNI 7129/01

The chimney constitutes the outlet point of exhaust fumes from a single flue or from a series of branched flues.

Although the chimneys may have various sizes and shapes, they must nevertheless comply with the following requirements:

- Have a net outlet cross-section at least double that of the single flue or branched flue in which it is inserted.
- Have a form such that prevents the infiltration of rainwater or snow into the flue or chimney.
- Be constructed in a manner that guarantees the free discharge of exhaust fumes regardless of the direction and inclination of the prevailing wind.

In order to prevent any backpressure from obstructing the free passage of the exhaust into the atmosphere, the following minimum height requirements must be satisfied (fig. 1):

### 1. Flat roof

If the chimney is further than 5 m from the highest point of the roof, it must be at least 0.5 m higher than the edge of the roof itself.

If the chimney is 5 m or less from the highest point of the roof, it must be at least 0.5 m higher than this highest point.

### 2. 15° pitched roof

If the ridge of the roof is further than 1.85 m from the chimney, the chimney must be at least 1 m higher than the edge of the roof.

If the ridge of the roof is 1.85 m or less from the chimney, the chimney must be at least 0.5 m higher than the ridge itself.

### 3. 30° pitched roof

If the ridge of the roof is further than 1.30 m from the chimney, the chimney must be at least 1.2 m higher than the edge of the roof.

If the ridge of the roof is 1.30 m or less from the chimney, the chimney must be at least 0.5 m higher than the ridge itself.

### 4. 45° pitched roof

If the ridge of the roof is further than 1.50 m from the chimney, the chimney must be at least 2 m higher than the edge of the roof.

If the ridge of the roof is 1.50 m or less from the chimney, the chimney must be at least 0.5 m higher than the ridge itself.

### 5. 60° pitched roof

If the ridge of the roof is further than 1.20 m from the chimney, the chimney must be at least 2.6 m higher than the edge of the roof.

If the ridge of the roof is 1.20 m or less from the chimney, the chimney must be at least 0.5 m higher than the ridge itself.

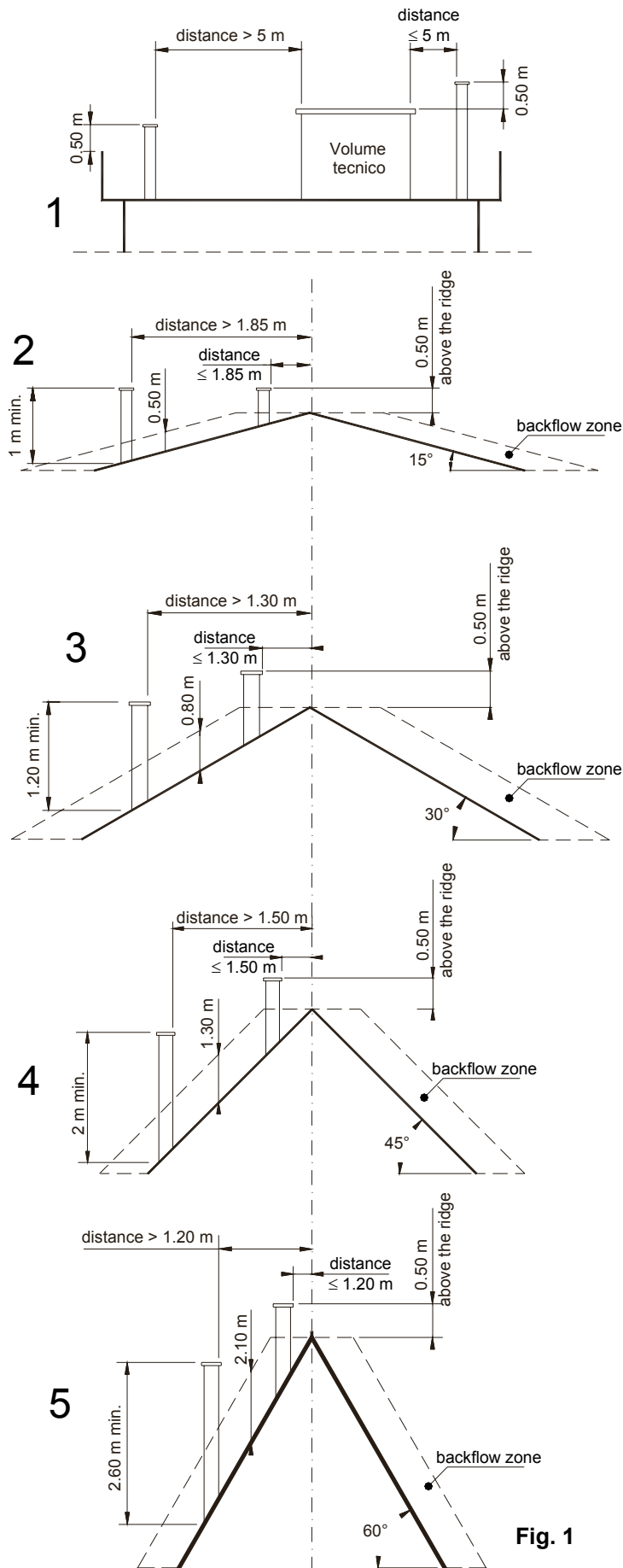
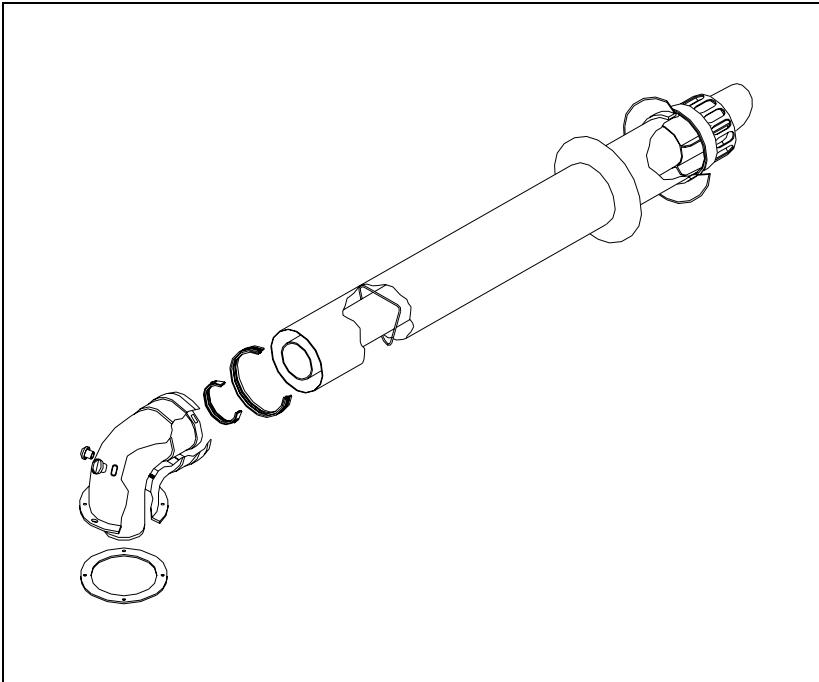

Fig. 1

## Flue type - kit K

Horizontal coaxial flue system Ø 100/60 in PPS polypropylene adjustable through 360°. Discharges exhaust fumes and draws air from atmosphere.



**Suitable for condensing boilers only.** Discharges exhaust gases and draws combustion air by means of two coaxial ducts. The external Ø100 duct draws the combustion air while the Ø60 plastic inner duct discharges the exhaust fumes. The discharge duct can be connected directly to the outside (UNI 7129/01 or local regulations) or can be connected to a suitable combined flue system.

**MAXIMUM FLUE LENGTH: 5 m.**

The *maximum flue length (linear equivalent)* is obtained by summing the length of linear pipe and the equivalent lengths of each bend fitted.

The *linear equivalent* is intended as being the total length of the duct from the connection with the combustion chamber of the appliance, excluding the first bend.

**The linear equivalent of additional bends is as follows:**

- Ø 100/60 x 90° bend = 0.8 m.
- Ø 100/60 x 45° bend = 0.5 m.

**N.B.: USE ONLY RADIANT TYPE-APPROVED FLUE SYSTEMS FOR DISCHARGING EXHAUST GASES AND DRAWING COMBUSTION AIR.**

### LEGEND

- HR** Ø 3/4" heating return
- CWI** Ø 1/2" D.H.W
- G** Ø 1/2" GAS
- HWO** Ø 1/2" D.C.W
- HF** Ø 3/4" heating flow
- SC** CONDENSATE DRAIN

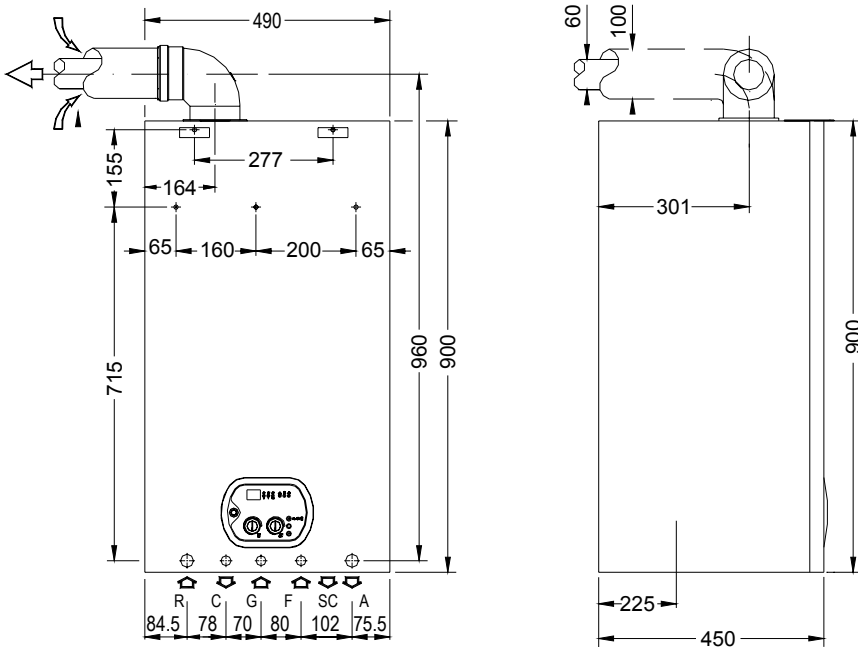

■ Flue type - kit H

Separate air intake/exhaust fumes discharge system in PPS polypropylene adjustable through 360°. The dual pipe system discharges exhaust fumes into a chimney and draws air from atmosphere.

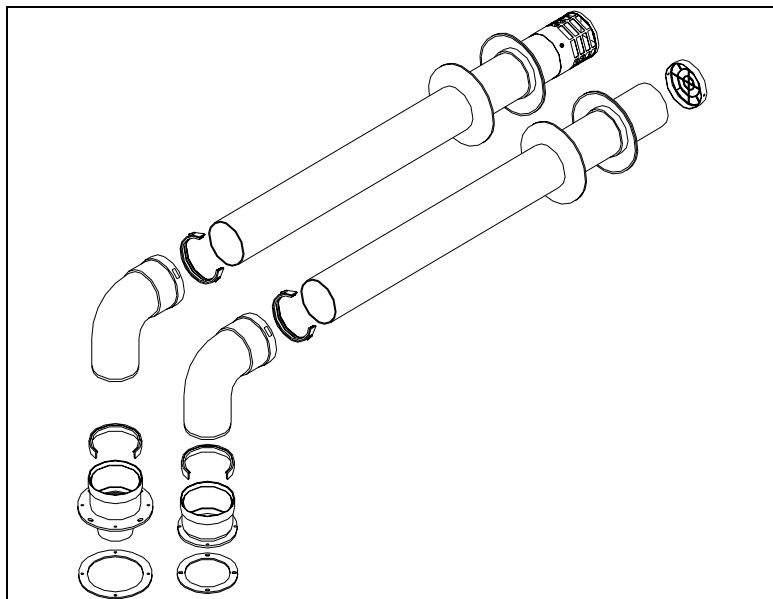

**Suitable for condensing boilers only.** Discharges exhaust gases and draws combustion air through two separate Ø 80 ducts.

**MAXIMUM FLUE LENGTH:**  
 Ø 80/80: 50 m.

The *maximum* flue length (linear equivalent) is obtained by summing the length of linear pipe and the equivalent lengths of each bend fitted.

The *linear equivalent* is intended as being the total length of the duct (exhaust discharge + air intake) from the connection with the combustion chamber of the appliance, excluding the first bend.

**The addition of a bend has the effect of increasing the linear equivalent length of the duct as follows:**  
 Ø 80 x 90° bend = 1.5 m.  
 Ø 80 x 45° bend = 1.2 m.

**N.B.: USE ONLY RADIANT TYPE-APPROVED FLUE SYSTEMS FOR DISCHARGING EXHAUST GASES AND DRAWING COMBUSTION AIR.**

**LEGEND**  
 HR Ø 3/4" Heating Return  
 CWI Ø 1/2" D.H.W  
 G Ø 1/2" GAS  
 HWO Ø 1/2" D.C.W  
 HF Ø 3/4" Heating Flow  
 SC CONDENSATE DRAIN

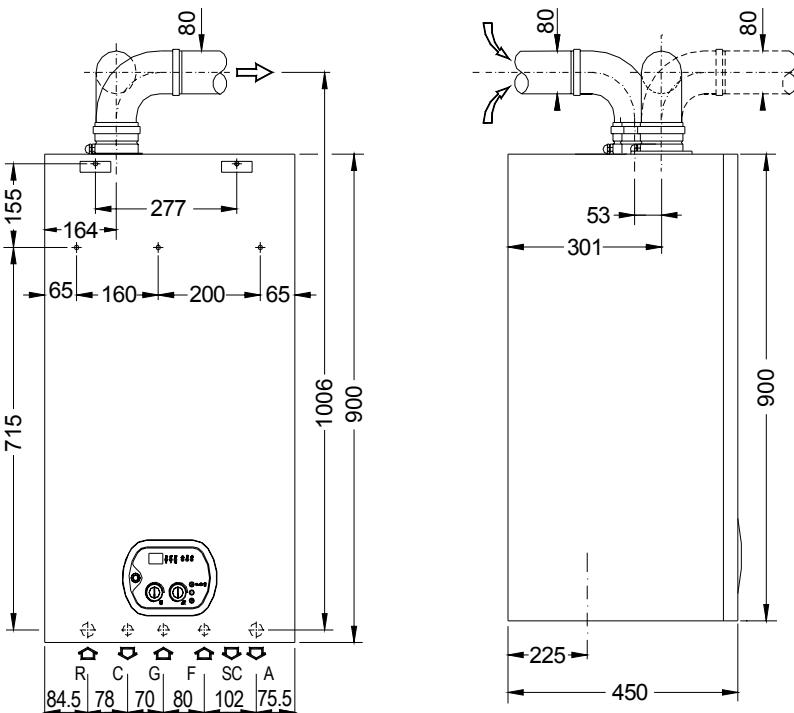



## Flue type - kit V

Vertical coaxial flue system in PPS polypropylene.

Discharges exhaust fumes and draws air directly from high Level.

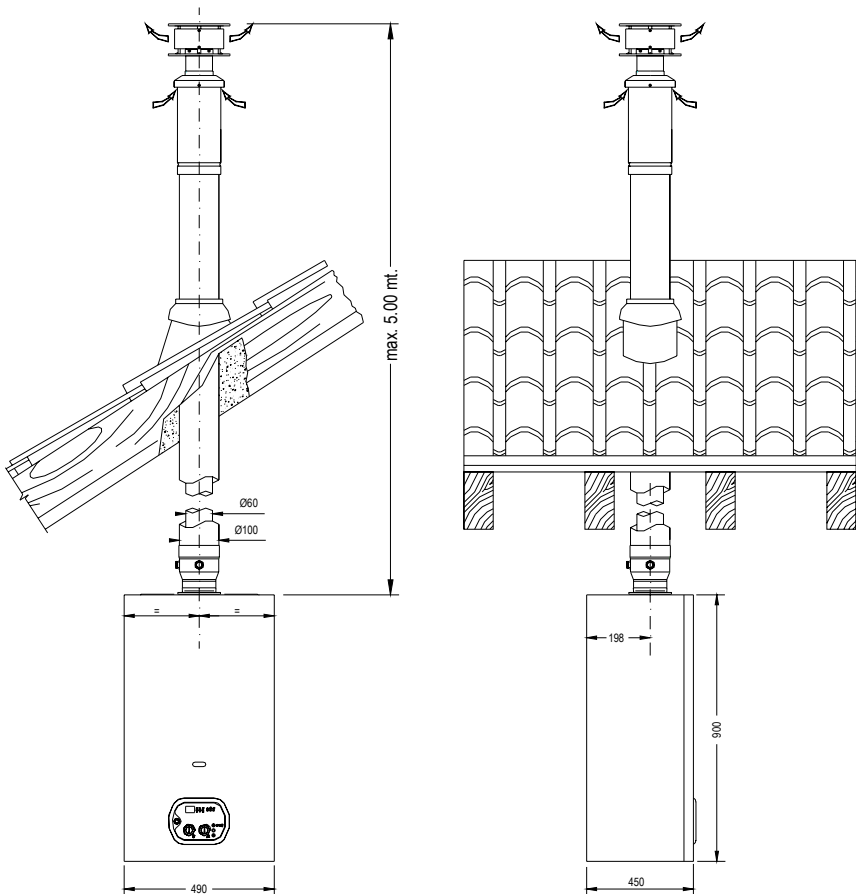
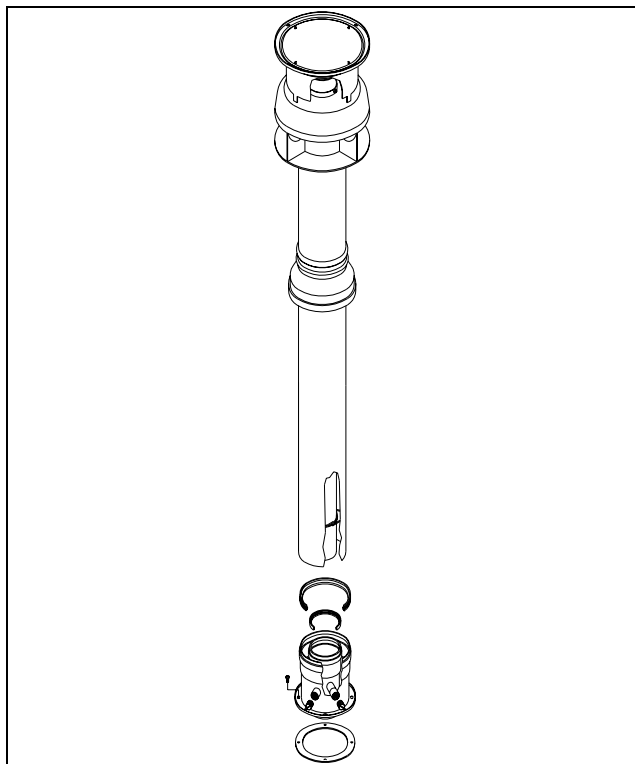

**Suitable for condensing boilers only.**

Discharges exhaust gases and draws combustion air at roof level by means of two coaxial ducts. The external Ø 100 duct draws the combustion air while the Ø 60 plastic inner duct discharges the exhaust fumes.

**MAXIMUM FLUE LENGTH: 5 m.**

The *maximum flue length (linear equivalent)* is obtained by summing the length of linear pipe and the equivalent lengths of each bend fitted.

The *linear equivalent* is intended as being the total length of the duct from the connection with the combustion chamber of the appliance, excluding the first bend.

**The linear equivalent of additional bends is as follows:**

- Ø 100/60 x 90° bend = 0.8 m.
- Ø 100/60 x 45° bend = 0.5 m.



**N.B.: USE ONLY RADIANT TYPE-APPROVED FLUE SYSTEMS FOR DISCHARGING EXHAUST GASES AND DRAWING COMBUSTION AIR.**

### LEGEND

- HR Ø 3/4" Heating Return
- HWO Ø 1/2" D.H.W
- G Ø 1/2" GAS
- CWI Ø 1/2" D.C.W
- HF Ø 3/4" Heating Flow
- SC Condensate drain

## 4. INITIAL START-UP

### 4.1 General warnings

-  The following operations must be carried out by professionally qualified personnel, registered in accordance with current legislation and authorised by Radiant Bruciatori S.p.A.
-  The boiler leaves the factory pre-set and tested for burning either Natural Gas or LPG. Nevertheless, when starting the boiler for the first time, make sure that the information on the rating plate corresponds to the type of gas being supplied to the boiler.
-  Once the system has been filled and the necessary adjustments made, remember to tighten the screws of the gas valve test point and make sure that there are no gas leaks from the test point and from any pipe fittings upstream of the gas valve.

#### ■ Preliminary operations

Lighting the boiler for the first time signifies checking that the installation, regulation and operation of the appliance are correct:

- If the gas supply system is newly installed, then the air present in the pipes can cause the boiler not to light at the first attempt. A number of attempts may be required in order to light the boiler.
- Check that the data on the rating plate corresponds to that of the mains supply networks (gas, electricity, water).
- Check that the power supply voltage to the boiler complies with the rating plate (230 V – 50 Hz) and that the live, neutral and earth wires are connected properly. Also make sure that the earth connection is sound.
- Check the seals on the gas supply pipe from the mains, and make sure that the meter does not register any flow of gas.
- Open the gas valve to the boiler and check that there are no leaks from the fittings upstream of the boiler (the burner gas connection is checked with the boiler in operation).
- Check that the gas supply is correctly sized for the flow rate required by the boiler and that it is fitted with all the safety and control devices as laid down by current regulations.
- Check that the supply of combustion air and exhaust and condensate discharge systems are functioning correctly and in line with current law and national and local standards.
- Check for the presence of permanent aeration/ventilation openings as required by current law for the type of appliances installed.
- Check that the flue duct and its connections to the terminal/chimney comply with the requirements of current law and national and local standards for the type of appliances installed.
- Make sure that any central heating shut-off valves are open.
- Check that the condensate drain system, including outside the boiler (flue system condensate collection devices), allows the condensate to flow freely to the collection devices. If the condensate is discharged to the domestic drainage system, install an inspection trap in the condensate system prior to it entering the drainage system to interrupt the continuity between the two systems.
- Check that there are no exhaust fumes discharged into the system itself.
- Check that there are no flammable materials or liquids in the immediate vicinity of the boiler.
  
- *Flush out both primary and domestic hot water circuits.*

## 4.2 Filling the system

**⚠ Use only a WRAS approved filling loop for connection and filling of the primary system. This should be disconnected when not in use.**

**⚠ Check the properties of the water supply and install the appropriate treatment devices if the mains water has a hardness rating more than 25 °F in order to prevent scaling and eventual damage to the D.H.W heat exchanger.**

**⚠ Use only clean tap water to fill the system.**

Once the water pipes have been connected, close the gas feed valve and fill the system as follows:

- Check that the circulation pump runs freely.
- Check that the plug of the air vent valve has been slackened slightly to allow air to escape from the system (fig.1).
- Open the main domestic water supply valve and the filling loop.
- Unscrew the plug on the circulation pump to remove any trapped air, check that the pump is free then re-tighten it when water starts to flow out.
- Open the air vents on the radiators and monitor the air evacuation process. When water starts to flow out of the radiators, close the air vents.
- Use the pressure gauge **M** (fig. 2) to check that the system pressure reaches at least 1 bar and that indicator **11** (see 2.7 “Control Panel”) lights up.
- If, after the above operations, there is a reduction in the pressure, re-open the external filling loop until the indicator **11** lights up and the pressure gauge shows at least 1 bar.
- **On completion, make sure that the filling loop is turned off and the hosepipe is removed.**

### EMPTYING THE CENTRAL HEATING SYSTEM

Whenever it is necessary to empty the system, proceed as follows:

- turn off the main power supply switch;
- wait for the boiler to cool down;
- turn the system drain tap **RS** (see fig. 4) and use a container to collect the water that runs out;

### EMPTYING THE DOMESTIC HOT WATER SYSTEM

Whenever there is danger of freezing or any other occurrence, the hot water system could be emptied in the following way:

- Shut off the water at the mains;
- Open all hot and cold water taps;
- Empty from the lowest point (where possible).

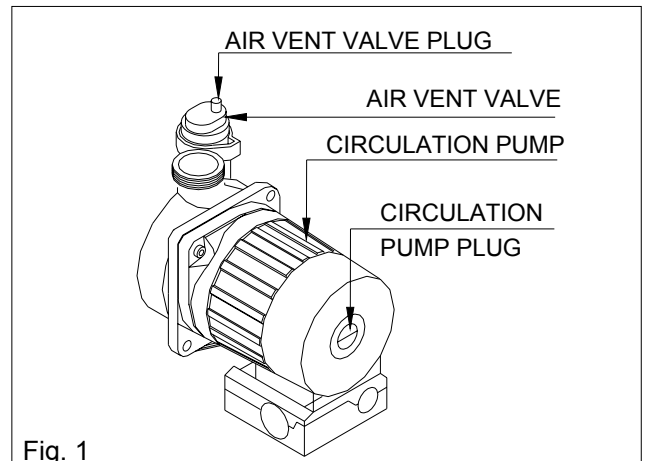

Fig. 1

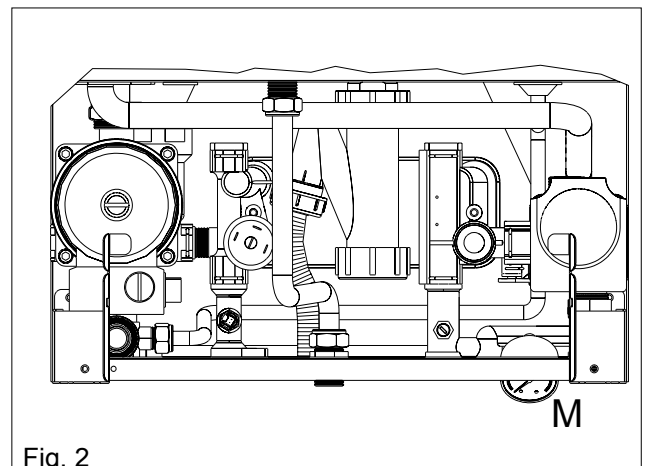

Fig. 2

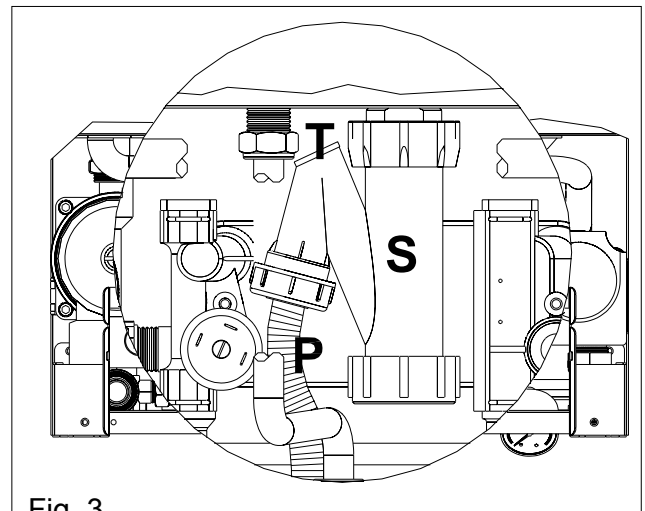

Fig. 3

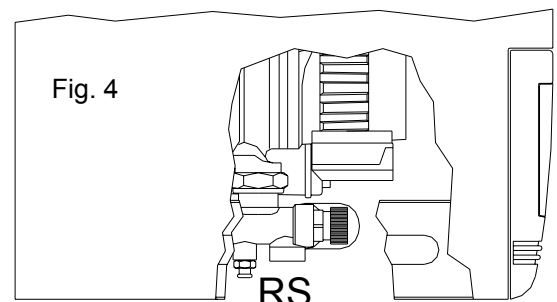

Fig. 4

## 4.3 Flushing the system

### TO FLUSH OUT THE PRIMARY SIDE OF THIS UNIT.

1. Fill the boiler as per the filling instructions.
2. Using a drain off cock on the lowest point of the system allow the water to drain from the system and boiler.
3. In order to flush the system correctly turn off all radiators open the filling loop and drain cock simultaneously and allow the water to flow through the boiler.
4. Open each individual radiator allowing water to flow through then turn that radiator off and repeat for all radiators on the system.
5. Turn off the filling loop and close the drain cock open all radiators and open the filling to fill the system.
6. Continue to fill the system until the pressure gauge reaches 1 bar.

### TO FLUSH OUT DOMESTIC HOT WATER CIRCUIT.

1. Ensure that the DHW expansion vessel has been fitted in line with the instructions on page 14 of the manual.
2. Open all hot water outlets.
3. Turn on inlet group supply so water enters the boiler; leave to fill until water is released from the hot water outlets. Turn off all hot water outlets.
4. Connect a hosepipe to the cylinder drain cock and open the drain cock.
5. Allow water to flow through the boiler and out of the drain cock.
6. Turn off water supply, disconnect the hosepipe, close the drain cock and refill the boiler.

## 4.4 Filling the condensate trap

The condensation trap must be pre-filled when starting the boiler for the first time in order to prevent flue gases from flowing back through the trap.

The filling operation is carried out as follows (fig. 3 previous page):

- Remove plug **T** and fill the trap **S** three quarters full with water.
- Replace plug **T** and connect the drainpipe **P**.

## 4.5 Starting up the boiler

Once the system has been filled, proceed as follows:

- Check that the exhaust flue is free of obstructions and correctly connected to the boiler.
- Switch on the power supply to the boiler.
- Open the gas isolation valve.
- Place switch **1** in the ON **position** (see 2.7 “Control Panel”), after a few seconds the circulation pump will start to run.
- Use button **5** to set the SUMMER, WINTER or SUMMER/WINTER function. L.e.d.s **8** and/or **9** will light up to indicate that the boiler is working.
- The automatic ignition system will then light the burner. It may however be necessary to repeat the operation a number of times in order to eliminate all the air from the pipes. To repeat the operation, wait approximately three minutes before re-attempting to light the boiler. To reset the boiler Switch off switch **1** (fig. 1 page 10) and switch it back on again and repeat the lighting procedure.
- With the boiler ignited, if the system still emits noises, the operations must be repeated until all the air has been removed.
- Check the pressure in the system. If the pressure has fallen, re-open the external filling loop until the indicator **11**, lights up and the pressure on the pressure gauge reads 1 bar, **and then close the filling loop and remove the flexible hose connection.**
- Unscrew the aluminium plug and insert an analyser in the exhaust sampling point **PF** (fig. 1) to check the CO<sub>2</sub> value. Make sure that the value complies with that reported in table 1.
- If the CO<sub>2</sub> value does not correspond to the specified value, adjust screw **V** (fig. 1) on the venturi clockwise to reduce the CO<sub>2</sub> value or anticlockwise to increase it.

Table n°1

Gas type	CO <sub>2</sub> %
G20	9.4
G 30	10.9
G 31	10.96

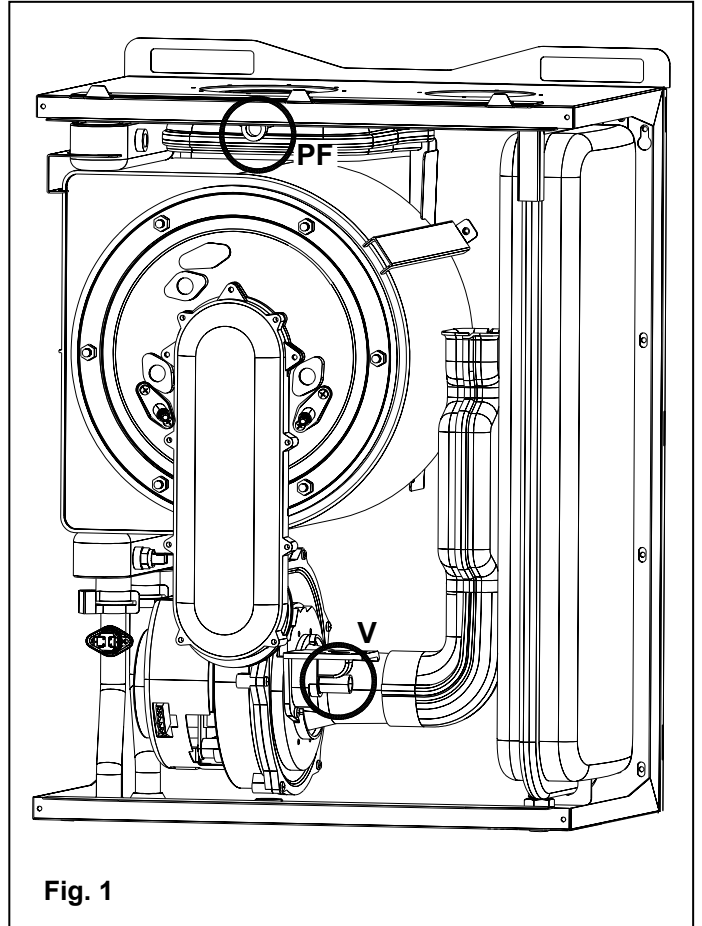

Fig. 1

## 5. COMMISSIONING THE BOILER

### 5.1 Parameter table

PARAMETER N°	FUNCTION	PARAMETER VALUE	OPTIONS
1	SELECTS TYPE OF BOILER	00 01 02	INSTANTANEOUS BOILER BOILER WITH STORAGE TANK BOILER TANK WITH +7°(stored water temp. increased by 7°)
2	SELECTS TYPE OF GAS	00 01	NATURAL GAS LPG
3	SETS THE CENTRAL HEATING TEMPERATURE	00 01	30-80°C FOR STANDARD SYSTEMS 25-40°C FOR FLOOR SYSTEMS
4	SELECTS THE PUMP MODE DURING HEATING PHASE	00 01 .	STANDARD ( 3 ' PUMP OVERRUN) PERMANENT (PUMP RUNS CONTINUOUSLY) Note: to be activated <b>ONLY FOR SYSTEM BOILERS</b>
5	WATER HAMMER PREVENTION	00 01	OFF ON (2" delay on D.H.W production)
6	CENTRAL HEATING TIMER (FACTORY SET AT 180" – PARAMETER VALUE "36" )	00 - 90	DELAYS THE HEATING RESTART TO PREVENT FREQUENT ON/OFFS, EXPRESSED IN 5 SEC STEPS. e.g. 90 (parameter value) x 5 = 450" (7.5 minutes)
7	CENTRAL HEATING POST-CIRCULATION TIMER (FACTORY SET AT 36 = 180"–)	00 - 90	THE HEATING POST-CIRCULATION TIME CAN BE MODIFIED AND IS EXPRESSED IN 5 SEC STEPS. Adjustable from 0 (OFF) to 90 = 90 x 5 = 450" (7.5 minutes)
8	D.H.W POST-CIRCULATION TIMER (FACTORY SET AT 18 = 90" )	00 - 90	THE D.H.W POST-CIRCULATION TIME CAN BE MODIFIED AND IS EXPRESSED IN 5 SEC STEPS. Adjustable from 0 (OFF) to 90 = 90 x 5 = 450" (7.5 minutes)
9	GAS MODULATION MINIMUM SETTING	-	Set the fan working frequency at the minimum heat output on d.h.w.. (PRESET AND FIXED VALUE = 20 for NAT GAS and LPG)
10	CENTRAL HEATING OUTPUT MINIMUM SETTING (DEFAULT VALUE = 24)	-	Set the fan working frequency at the minimum heat output on central heating. (PRESET AND FIXED VALUE = 24 for NAT GAS – 21 for LPG)
11	MAX GAS FLOW RATE AND HEATING OUTPUT (DEFAULT VALUE = 66)	par. 10 value – 99	Set the fan working frequency at the maximum heat output on central heating. (PRESET VALUE = 65 for NAT GAS and LPG)

## 5.2 Parameters programming

### 5.2.1 Entering Parameters Menu

Each time you wish to change or check any parameter value, you should access the parameter menu, following this procedure:

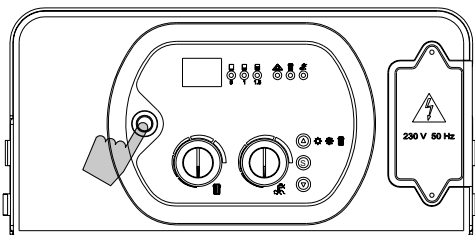

1. Place the ON/OFF switch in OFF position;

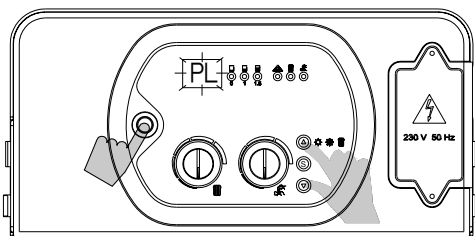

2. Keep pressed the (▲) and (▼) buttons, switch on the boiler and wait for the display to show 'PL' – '0';
3. Release (▲) and (▼) buttons;

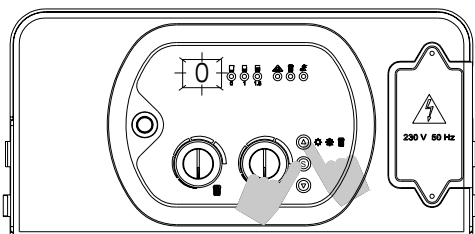

4. Keeping the 'service' (S) button pressed, use the (▲) or (▼) buttons to choose the parameter you wish to change or check. Parameter number will be shown on the display;

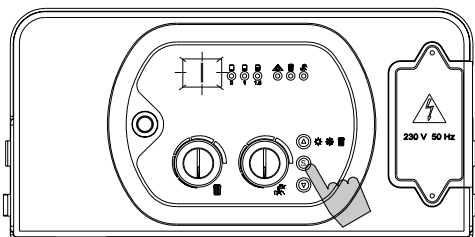

5. Release the service (S) button, then re-press and release it. On display you may read the parameter value;
6. If needed, change the value accordingly with the following procedures (one for each parameter), otherwise, switch off and then on the appliance to reset and restart the boiler.

## 5.2.2 Parameters settings

To enter the parameters menu, follow the procedure shown at page n° 35 (steps 1-6).

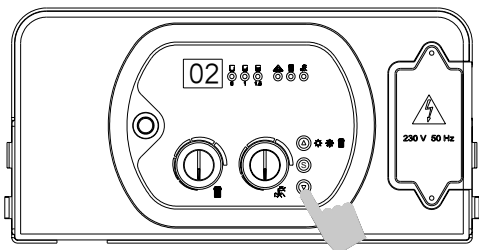

### ◀ PARAMETER N° 1 – TYPE OF BOILER

7. Use (▲) and (▼) buttons to modify the value of the parameter:

00 = Instantaneous boiler;  
01 = Storage boiler;  
02 = 'Storage comfort' boiler. With this option you'll have stored water with 7° higher temperature;

8. Press and release the service (S) button to confirm your choice. Number 1 will appear on the display;

9. If you have to modify some other parameter, follow the 4 – 5 steps (p. 35), then go to the specific procedure for that parameter, otherwise switch off and on the appliance to register the modifications.

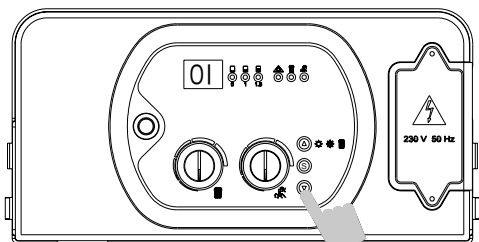
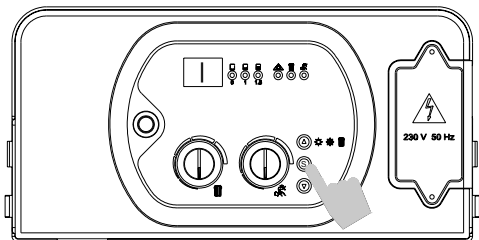

### ◀ PARAMETER N° 2 – KIND OF GAS SUPPLY

7. Use (▲) and (▼) buttons to modify the value of the parameter:

00 = Natural gas  
01 = LPG;

8. Press and release the service (S) button to confirm your choice. Number 2 will appear on the display;

9. If you have to modify some other parameter, follow the 4 – 5 steps (p. 35), then go to the specific procedure for that parameter, otherwise switch off and on the appliance to register the modifications.

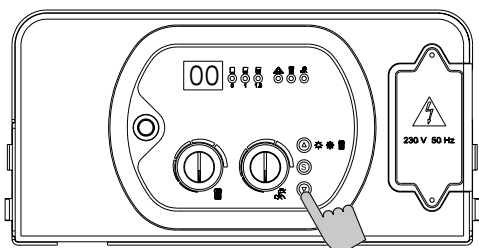
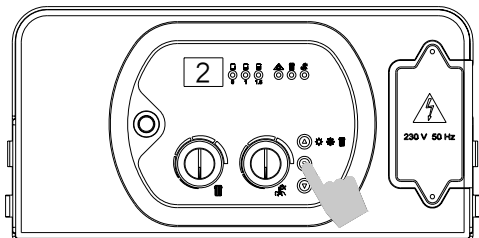

### ◀ PARAMETER N° 3 – CENTRAL HEATING TEMPERATURE RANGE

7. Use (▲) and (▼) buttons to modify the value of the parameter:

00 = STANDARD (30 – 80 °C)  
01 = REDUCED (25 – 40 °C) for floor systems;

8. Press and release the service (S) button to confirm your choice. Number 3 will appear on the display;

9. If you have to modify some other parameter, follow the 4 – 5 steps (p. 35), then go to the specific procedure for that parameter, otherwise switch off and on the appliance to register the modifications.

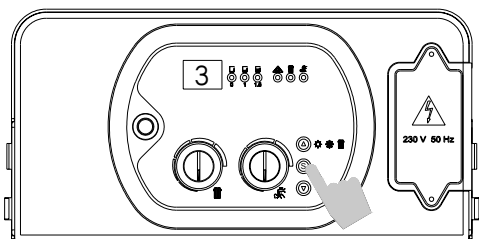



◀ PARAMETER N° 4 – PUMP MODE ON CENTRAL HEATING PHASE

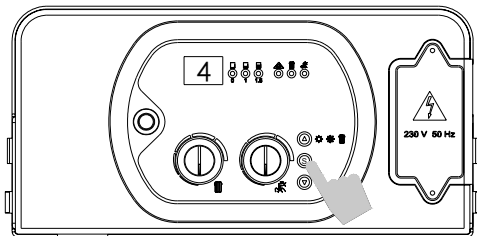
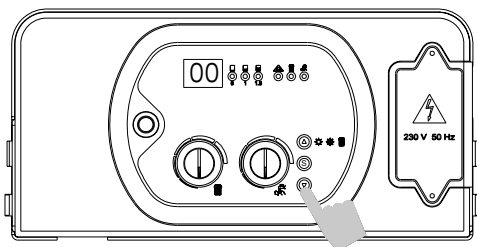

7. Use (▲) and (▼) buttons to modify the value of the parameter:

00 = STANDARD (3' OVERRUN)  
 01 = ALWAYS RUNNING  
 (to be activated **ONLY FOR SYSTEM BOILERS**);

8. Press and release the service (S) button to confirm your choice. Number 4 will appear on the display;

9. If you have to modify some other parameter, follow the 4 – 5 steps (p. 35), then go to the specific procedure for that parameter, otherwise switch off and on the appliance to register the modifications.

◀ PARAMETER N° 5 – WATER HAMMER EFFECT PREVENTION

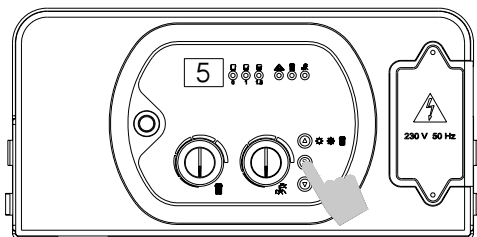
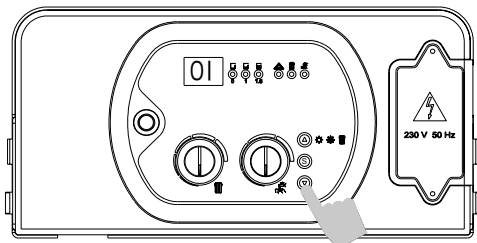

7. Use (▲) and (▼) buttons to modify the value of the parameter:

00 = OFF  
 01 = ON: 2" delay on D.H.W. start;

8. Press and release the service (S) button to confirm your choice. Number 5 will appear on the display;

9. If you have to modify some other parameter, follow the 4 – 5 steps (p. 35), then go to the specific procedure for that parameter, otherwise switch off and on the appliance to register the modifications.

◀ PARAMETER N° 6 – CENTRAL HEATING TIMER

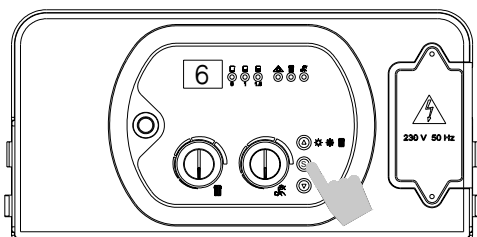
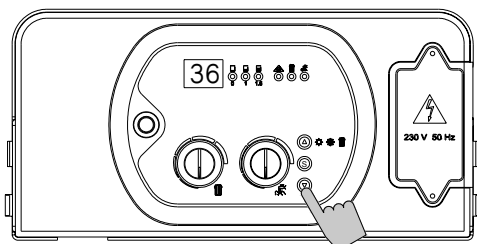

7. Use (▲) and (▼) buttons to modify the value of the parameter between:

00 = 0"  
 99 = 99 x 5" = 450" = 7.5'

Default value is set to 36 = 180" = 3'.

8. Press and release the service (S) button to confirm your choice. Number 6 will appear on the display;

9. If you have to modify some other parameter, follow the 4 – 5 steps (p. 35), then go to the specific procedure for that parameter, otherwise switch off and on the appliance to register the modifications.

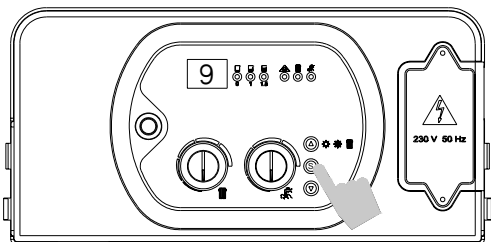
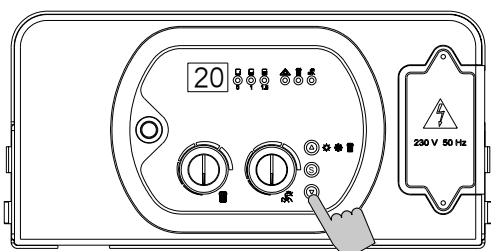
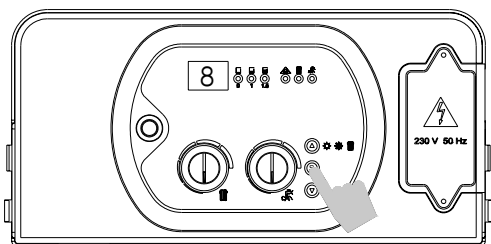
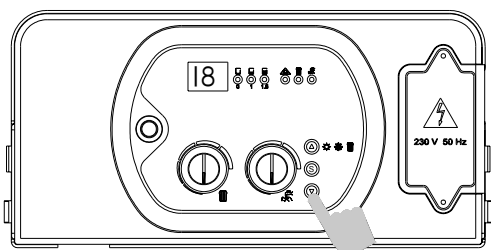
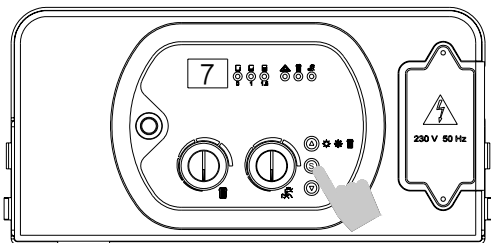
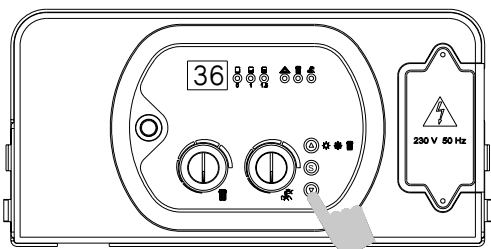

◀ PARAMETER N° 7 – CENTRAL HEATING PUMP OVERRUN

7. Use (▲) and (▼) buttons to modify the value of the parameter:

00 = 0

99 =  $99 \times 5'' = 450'' = 7.5'$

Default value is set to 36 =  $180'' = 3'$

8. Press and release the service (S) button to confirm your choice. Number 7 will appear on the display;
9. If you have to modify some other parameter, follow the 4 – 5 steps (p. 35), then go to the specific procedure for that parameter, otherwise switch off and on the appliance to register the modifications.

◀ PARAMETER N° 8 – D.H.W. PUMP OVERRUN

7. Use (▲) and (▼) buttons to modify the value of the parameter:

00 = 0

99 =  $99 \times 5'' = 450'' = 7.5'$

Default value is set to 18 =  $90'' = 1.5'$

8. Press and release the service (S) button to confirm your choice. Number 8 will appear on the display;
9. If you have to modify some other parameter, follow the 4 – 5 steps (p. 35), then go to the specific procedure for that parameter, otherwise switch off and on the appliance to register the modifications.

◀ PARAMETER N° 9 – MINIMUM GAS RATE ON D.H.W.

7. The value of the parameter must be equal to the one shown into page 34 table.

Use (▲) and (▼) buttons to set the parameter to the default value of 20 both for Natural Gas & L.P.G..

8. Press and release the service (S) button to confirm your choice. Number 9 will appear on the display;
9. If you have to modify some other parameter, follow the 4 – 5 steps (p. 35), then go to the specific procedure for that parameter, otherwise switch off and on the appliance to register the modifications.

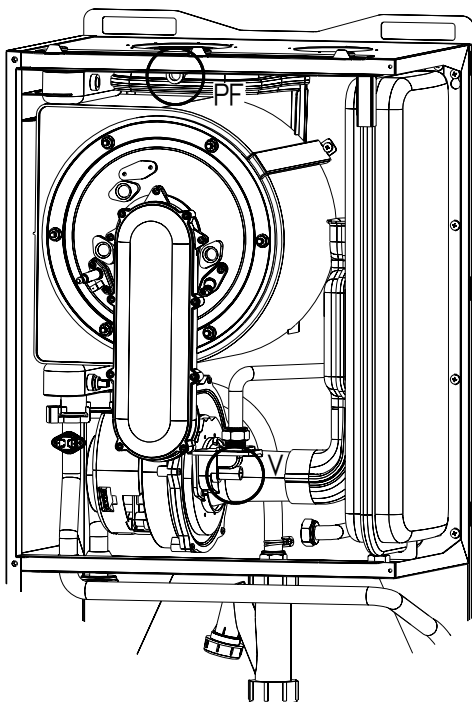
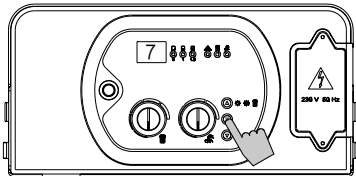
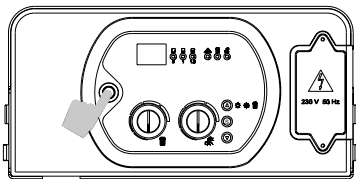
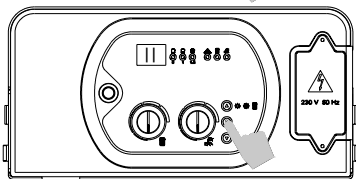
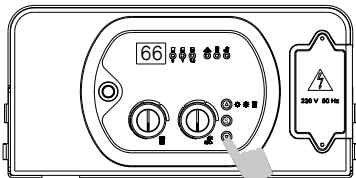
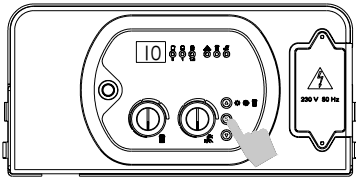
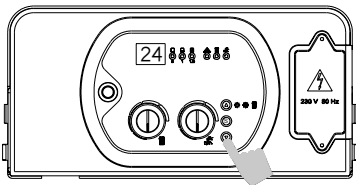

- ◀ PARAMETER N° 10 – MINIMUM HEATING POWER
- 7. The value of the parameter must be equal to the one shown into page 35 table.  
Use (▲) and (▼) buttons to modify the value of the parameter:

**24 for Natural Gas**  
**21 for L.P.G.**

- 8. Press and release the service (S) button to confirm your choice. Number 10 will appear on the display;
- 9. If you have to modify some other parameter, follow the 4 – 5 steps (p. 35), then go to the specific procedure for that parameter, otherwise switch off and on the appliance to register the modifications.

- ◀ PARAMETER N° 11 – MAXIMUM GAS RATE AND HEATING POWER

- 7. If you only have to set the parameter value, simply use (▲) and (▼) buttons to modify the value of the parameter between:

**24 and 99 (NAT GAS)**  
**or 21 and 99 (L.P.G.)**

accordingly with the energy requirement of your specific system. To set this value, please refer to the p. 40 'Parameter Value – Heating Power' diagram.  
The default value is **65** for both NAT GAS and L.P.G.

- 8. Press and release the service (S) button to confirm your choice. Number 11 will appear on the display;
- 9. If you have to modify some other parameter, follow the 4 – 5 steps (p. 35), then go to the specific procedure for that parameter, otherwise switch off and on the appliance to register the modifications.
- 7. If you have to check the CO<sub>2</sub> rate, use (▲) and (▼) buttons to modify the value of the parameter and bring it to **99**;
- 8. Switch off then on the appliance;
- 9. Keep pressed the service (S) button until the display will show flashing n° 7 (*chimney sweeper function*) or open a D.H.W. tap at maximum flow rate and temperature to make the boiler start up;
- 10. Unscrew the aluminium plug and insert the analyzer into the exhaust sampling point (PF) to check the CO<sub>2</sub> value;
- 11. Work on the V screw of the venturi to adjust the CO<sub>2</sub> value and make it comply with that of table 1 page 40. Turn the screw clockwise to reduce the CO<sub>2</sub> value, counter clockwise to increase it.
- 12. Switch off and then re-enter the parameter 11 adjusting menu to regulate it.

## 5.3 Gas data

### 5.3.1 Data Tables

Table n°1 – CO<sub>2</sub> values

Gas type	CO <sub>2</sub> %
G20 Natural Gas	9.4
G 30 Butane	10.9
G 31 Propane	10.96

Table n°2 - Gas data table		NATURAL GAS G20	LIQUID BUTANE GAS G30	LIQUID PROPANE GAS G31
Lower Wobbe index (15°C; 1013 mbar)	MJ/Nm <sup>3</sup>	45.67	80.58	70.69
Nominal supply pressure	mbar	20	30	37
Consumption (15°C; 1013 mbar)	m <sup>3</sup> /h	2.64	-	-
	kg/h	-	1.94	1.94
	cfh	93.22	36.63	36.63

### 5.3.2 Heating power (kW) – Parameter value diagram

(G20-G30/31)

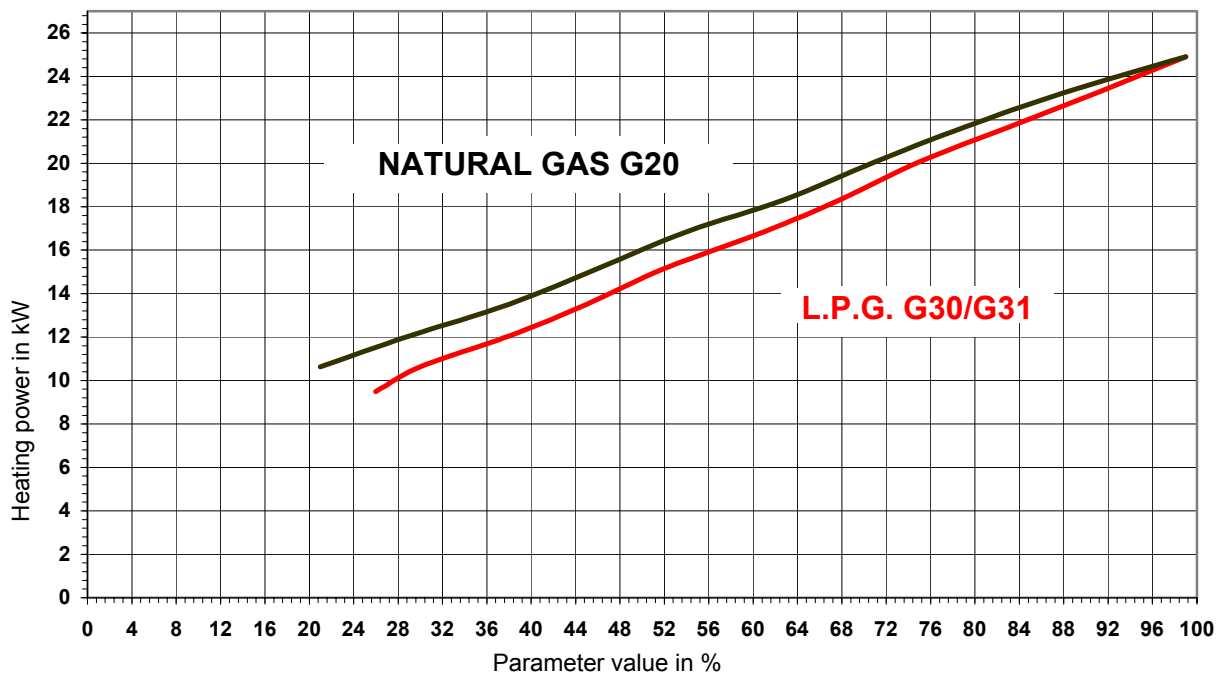

Fig. 1

## 5.4 Regulating the stepped ignition sequence

Each time the appliance is started up, in order to provide optimum ignition and an even flame distribution over the entire surface of the burner, a stepped ignition sequence is used. This consists of an instantaneous and brief increase in the gas pressure during the ignition phase only.

The correct setting for the appliance can be checked as follows (fig. 1):

- a. With the appliance switched on, open the control panel and expose the electric fan modulation board (see "6.3 Accessing the boiler").
- b. Connect the terminals of a frequency meter to the appropriate terminal board (1).
- c. Move jumper CM1 (2) to cover both pins in order to close the circuit.
- d. Check that the frequency indicated is 80 Hz for G20 or 110 Hz for G30/G31.
- e. If the frequencies do not coincide (the type of gas is different to that for which the boiler has been factory set) adjust the potentiometer screw P2MIN (3) until the rating plate value is reached.
- f. Remove jumper CM1 and replace it in its original position (circuit open).
- g. Switch off the appliance, disconnect the frequency meter and close the control panel.
- h. Restart the appliance.

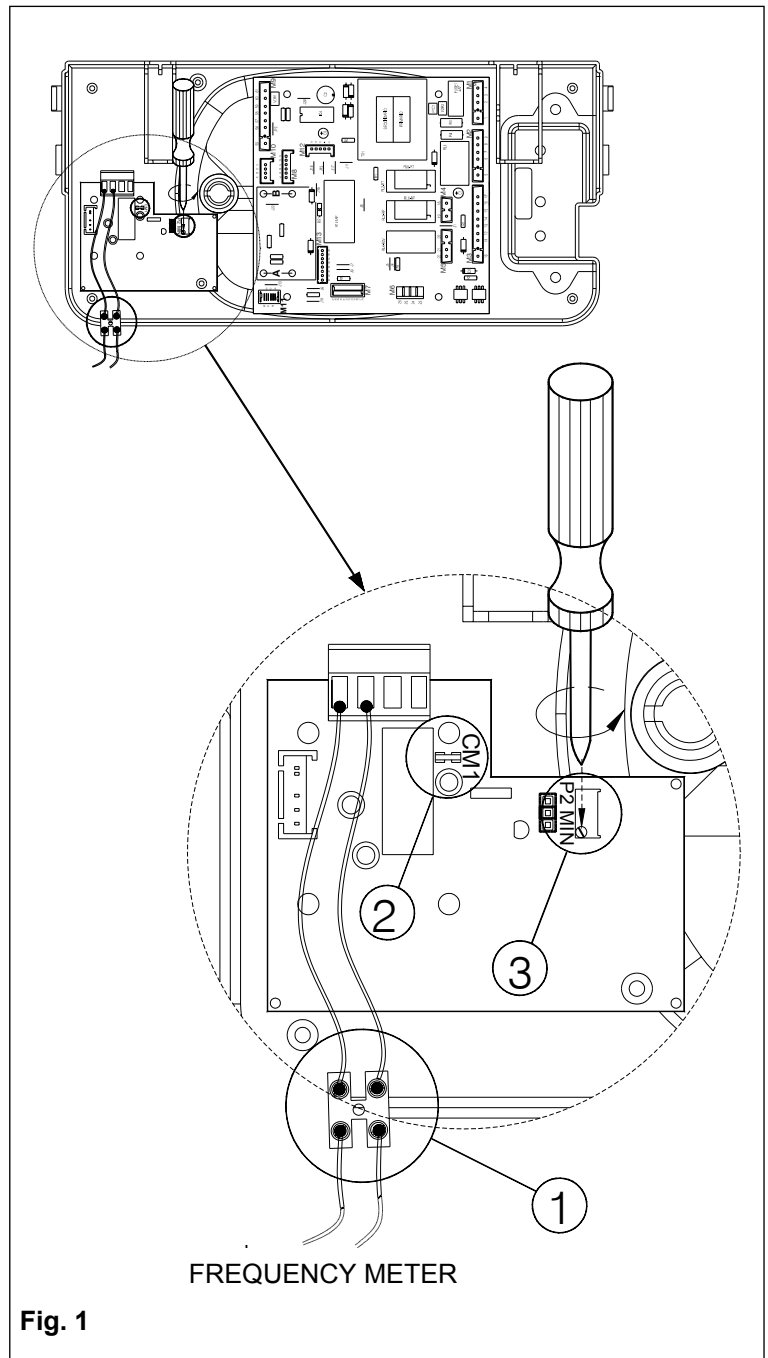

## 5.5 Converting the boiler for different gas type

**⚠** The conversion of a boiler from burning natural gas to LPG, or vice versa, must be carried out exclusively by professionally qualified personnel, registered in accordance with current legislation.

**⚠** Check that the gas supply pipe is suitable for the new fuel type.

When converting from one gas type to another, simply change the settings of the electric fan modulation board to those of the new gas type:

- Open the control panel (see “6.3 Accessing the boiler”).
- Fit jumper P1 MAX as shown in figure 1:
  - Pos. A – NATURAL GAS G20
  - Pos. B – LPG G30/G31.
- Then set parameter 2 “Selecting the type of gas”
- Close the control panel and restart the appliance.
- 
- Then set parameters 10 and 11 (see “Regulating the gas pressure”).

**N.B.** The jumper must always be fitted regardless of the type of gas being used. Removing the jumper will cause the fan to malfunction.

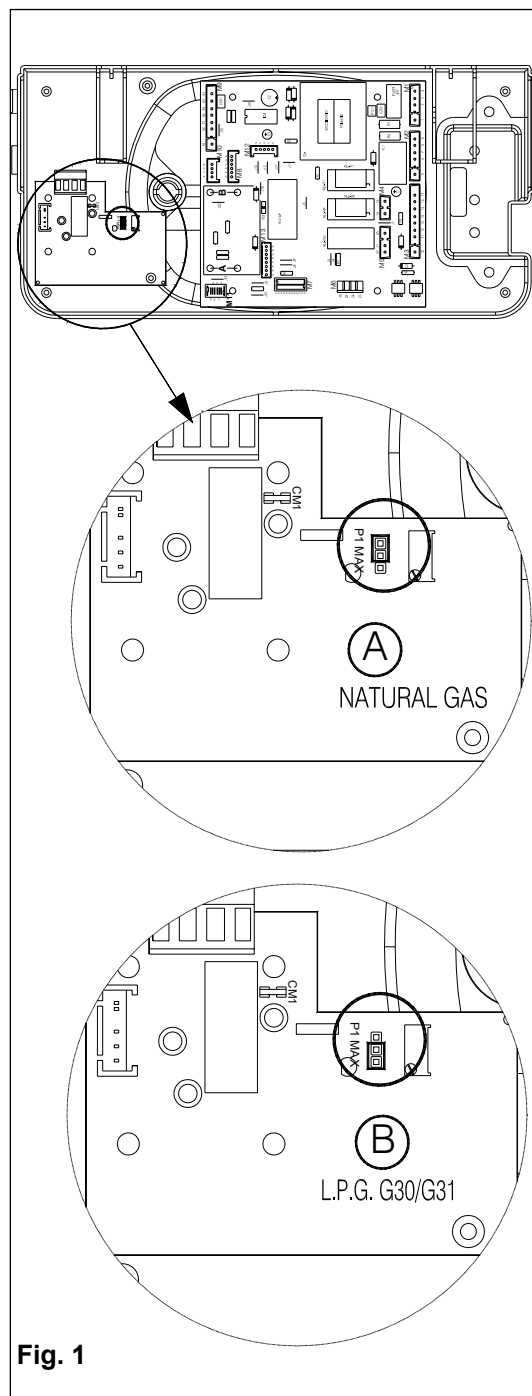







Fig. 1

## 6. SERVICING THE BOILER

### 6.1 General warnings

-  All maintenance operations must be carried out according to UNI-CIG 7129/01, and subsequent updates, by professionally qualified personnel, registered in accordance with current legislation. All warranty work is to be carried out and authorised by Radiant Bruciatori S.p.A Service centre.
-  The RADIANT HELPLINE UK 0870 770 0414
-  The frequency of the boiler maintenance must comply with current law and, nevertheless, should be carried out once a year.
-  In order to guarantee the long life of the appliance and in accordance with the current gas safety regulations, only use original spare parts.
-  Before carrying out any type of maintenance operation, disconnect the appliance from the mains electricity supply and close the gas valve.

### 6.2 Boiler inspection

In order to ensure that the boiler operates efficiently and safely, it is recommended that the appliance is inspected by a suitably competent technician at least once a year.  
The following operations should be carried out annually

- Check the condition of the gas seals and replace where necessary.
- Check the condition of the water seals and replace where necessary.
- Visually inspect the condition of the combustion chamber and flame.
- When required, check that the combustion is correctly regulated and if necessary proceed in line with section "Commissioning the boiler".
- Remove and clean any oxidation from the burner.
- Check that the seal of the room-sealed chamber is undamaged and positioned correctly.
- Check the primary heat exchanger and clean if necessary.
- Check the maximum and minimum modulation pressures and the modulation itself.
- Check the condition and operation of the ignition and gas safety systems. If necessary, remove and clean the scaling from the ignition and flame detection electrodes, paying particular attention to replace them at the correct distance from the burner. (*Check the positions of the electrodes, especially the ignition electrode. Make sure that there is a gap of 3 mm between the two ignition electrodes, which should be 10 mm from the burner.*)
- Check the heating safety systems: temperature limit safety thermostat, pressure limit safety device.
- Check the pre-fill pressure of both the system and the DHW expansion vessels.
- For safety reasons, periodically check the integrity and operation of the flue gas exhaust system.
- Check that the connection to the mains electricity supply complies with that reported in the boiler's instruction manual.
- Check the electrical connections inside the control panel.
- Check the D.H.W flow rate and temperature.
- Check that the condensate drain system is working correctly, including any parts of the system outside the boiler such as condensate collection devices along the length of the flue and/or any acid neutralising devices.
- Check that the condensate flows freely and that there are no exhaust fumes present within the appliance.
- Check the condition of the sacrificial anode installed at the top of the cylinder

## 6.3 Maintenance for unvented components

It is essential that the unvented hot water components have a regular maintenance programme. It is Radiant's recommendation that this be carried out in conjunction with the annual boiler service.

- ◆ The **STORAGE CYLINDER** and **CENTRAL HEATING PRESSURE RELIEF VALVES** should be manually operated for a period of not less than 5 seconds each to:
  - i. Check the flow of water through the valve and the final discharge route to the drain.
  - ii. Check the relief valves reseal property.
  
- ◆ The **DHW EXPANSION VESSEL** pre-set pressure should be checked as follows,
  - i. Close main stopcock;
  - ii. Relieve pressure from system by opening a hot tap
  - iii. Check pressure of vessel using an accurate type pressure gauge;
  - iv. Adjust if necessary to 3.5 bar (with car foot pump);
  
- ◆ The **INLET CONTROL GROUPS FILTER** should be checked for blockages as follows,
  - i. Close main stopcock;
  - ii. Relieve system pressure by opening a hot tap;
  - iii. Disconnect and remove pressure-reducing valve from the inlet group;
  - iv. Clean inlet filter; replace it and test;
  - v. Open main stopcock;
  
- ◆ Check the **SACRIFICIAL ANODE** located at the top of the storage cylinder by using the easy test nipples as follows:
  - i. Unscrew the red cap located on the top of the anode;
  - ii. If water is released the anode requires replacing;
  - iii. If no water is released then the anode is still serviceable ensure the red cap is screwed down tightly and noted on the service record as checked.



## 6.4 Accessing the boiler

All maintenance operations require one or more of the boiler casing panels to be removed.

The side panels can only be removed after the front panel has been removed.

### Front panel:

- Remove the fixing screws at the lower edge of the front panel.
- Grasp the lower part of the panel and pull it outwards (fig. 1) and then up .

### Left and right side panel:

- Remove the fixing screws at the front and lower edge of the side panel to remove.
- Grasp the bottom of the panel, move it sideways and then upwards to remove it.

### **To access the electrical connections of the control panel, proceed as follows:**

- Remove the front panel (see fig. 1).
- Grasp the left and right control panel support brackets (fig. 2) and pull them outwards, at the same time rotating the panel downwards.
- Unscrew the four fixing screws (fig. 3) and remove the cover.

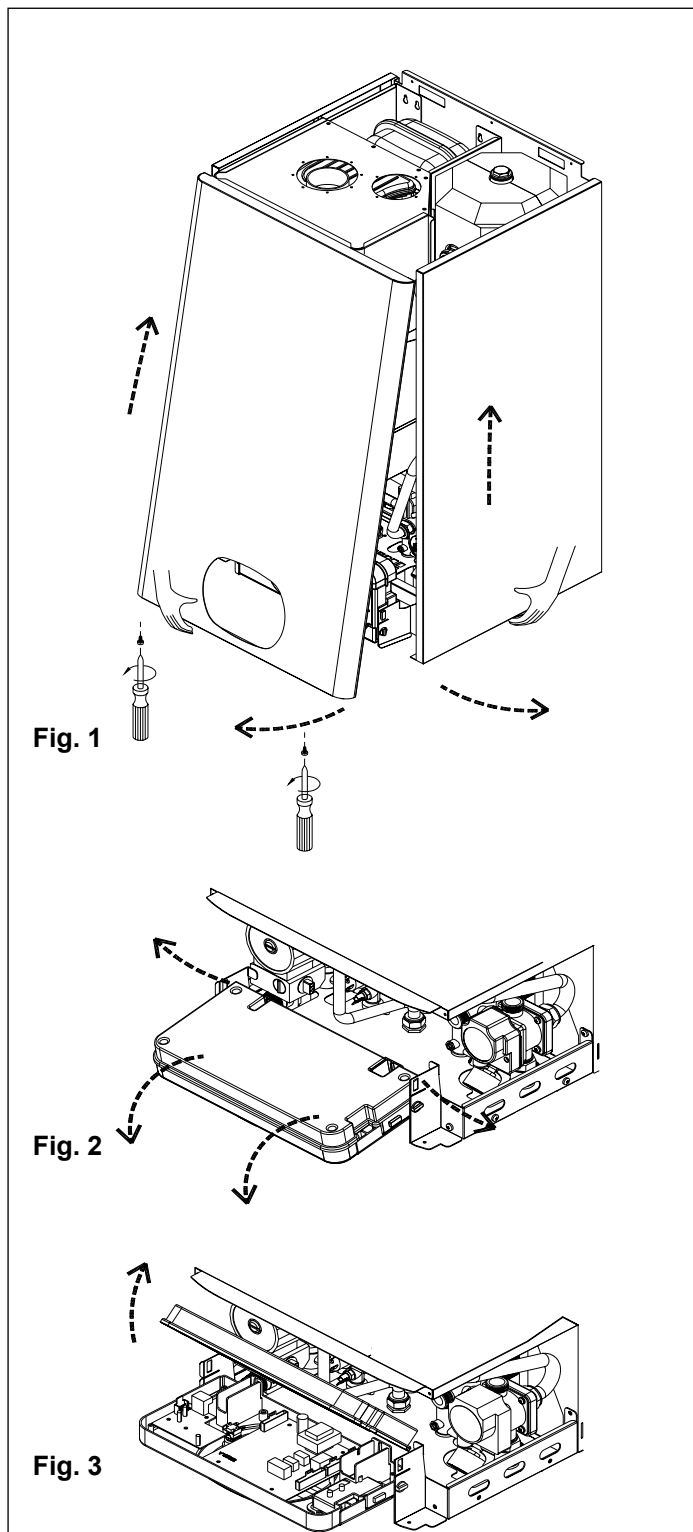

## 6.5 Draining the central heating and the domestic hot water systems

### DRAINING THE CENTRAL HEATING SYSTEM

If the need arises to drain the system, this can be done as follows:

- Switch the system to “WINTER” mode and ignite the boiler.
- Switch off the power supply to the boiler.
- Wait for the boiler to cool down.
- Connect a hosepipe to the system drain point and locate the other end of the hose in a suitable drainage system.
- Open the system drain valve (fig. 1).
- Open the air vents on the radiators, starting with the highest and moving down the system to the lowest.
- When the system has been drained, close the radiator breather valves and the drain valve.
- **If only the boiler needs to be drained, close the flow/return isolating valves on the heating circuit and open the drain valve located at the bottom of the boiler on the pump manifold.**

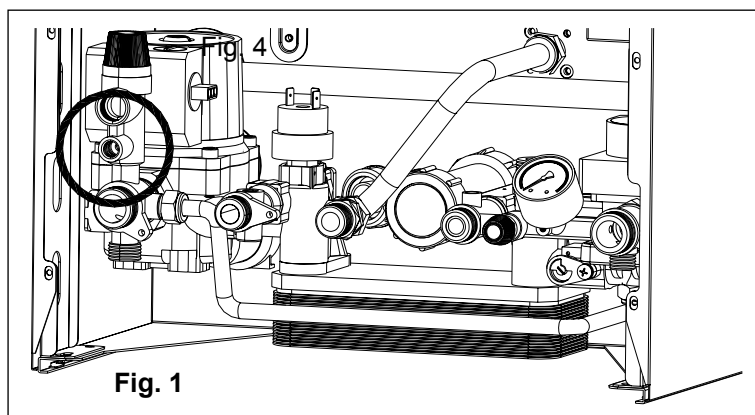

### DRAINING THE DOMESTIC HOT WATER SYSTEM

If there is a danger of freezing, the domestic hot water system should be drained. This can be done as follows:

- Shut off the water at the mains;
- Open all the hot and cold water taps.
- Empty from the lowest point (where possible).
- **On completion, close all the previously opened taps.**

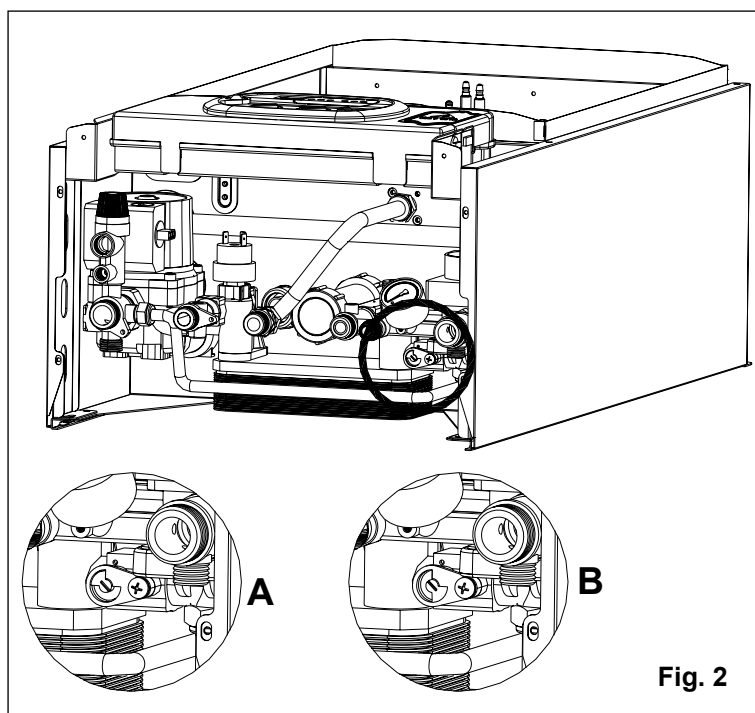

### ■ Excluding the automatic Bypass

All models fitted with the **Multiplex**<sup>®</sup> system have an automatic bypass system fitted as standard. The system is necessary in the case where two-way zone valves are installed or thermostatic valves are mounted on the radiators.

In the fully open condition (fig. 2, pos B), the system guarantees the maximum operating flow.

If need be, however, the bypass can be excluded as follows:

- Switch off the boiler by placing the switch in the  OFF position.
- Rotate the screw on the bypass from position **B** to position **A**.

***N.B. THE BOILER LEAVES THE FACTORY WITH THE BYPASS SET IN THE CLOSED POSITION (POSITION A).***

## 6.6 Wiring diagrams

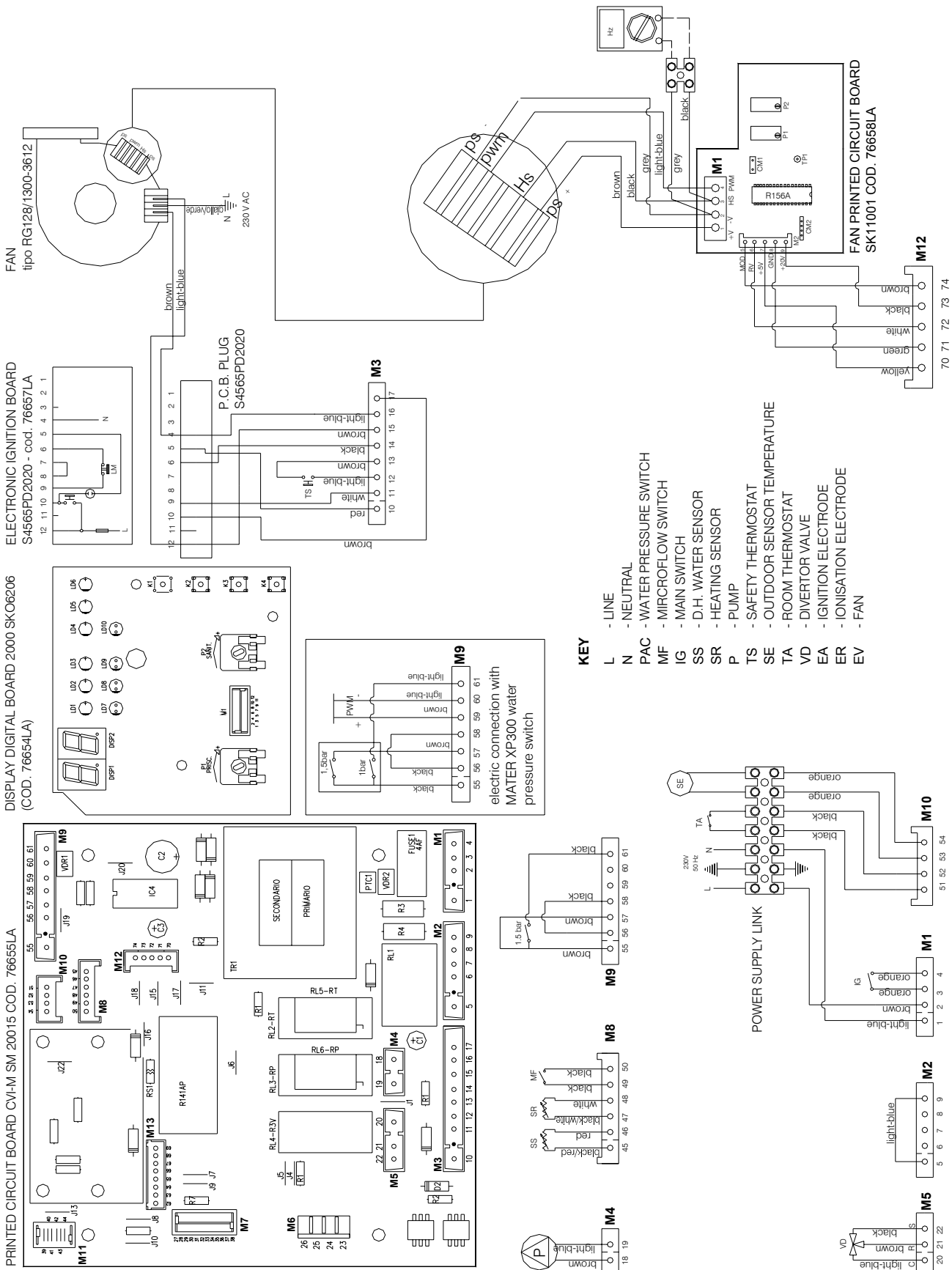

## 6.7 Troubleshooting

ERROR CODE	PROBLEM	POSSIBLE CAUSE	REMEDY
01	NO FLAME	<p><i>WITH NO IGNITION</i></p> <p>a. NO GAS. b. IGNITION ELECTRODE BROKEN OR EARTHED. c. IGNITION CIRCUIT BOARD S4565QM MALFUNCTION. d. GAS VALVE MALFUNCTION. e. MECHANICAL MINIMUM ADJUSTMENT (ON GAS VALVE). TOO LOW OR SLOW IGNITION ADJUSTMENT TOO LOW. f. VALVE INLET PRESSURE TOO HIGH (FOR LPG BOILERS ONLY).</p> <p><i>WITH IGNITION</i></p> <p>g. POWER SUPPLY LIVE AND NEUTRAL WIRES INVERTED. h. SENSOR ELECTRODE MALFUNCTION. i. SENSOR ELECTRODE WIRE DISCONNECTED. j. IGNITION CIRCUIT BOARD S4565QM MALFUNCTION.</p>	<p>a. CHECK MAINS SUPPLY. b. REPLACE PART. c. REPLACE PART. d. REPLACE PART. e. REGULATE MINIMUM OR SLOW IGNITION. f. CHECK THE MAXIMUM PRESSURE SETTING.</p> <p>g. CONNECT THE POWER SUPPLY WIRES CORRECTLY. h. REPLACE PART. i. CONNECT THE SENSOR ELECTRODE WIRE. j. REPLACE PART.</p>
02	SAFETY THERMOSTAT TRIPPED (95°C)	<p>k. THERMOSTAT MALFUNCTION OR INCORRECT. l. THERMOSTAT DISCONNECTED (WIRE DISCONNECTED). m. PUMP FAILURE</p>	<p>k. REPLACE PART. l. CHECK THE WIRING. m. CHECK AND REPLACE PUMP</p>
04	NO WATER IN THE SYSTEM	<p>n. INSUFFICIENT WATER PRESSURE IN THE SYSTEM (STOPS AT 0.5 BAR). o. WATER PRESSURE SWITCH DISCONNECTED. p. WATER PRESSURE SWITCH MALFUNCTION.</p>	<p>n. FILL THE SYSTEM. o. CHECK THE WIRING. p. REPLACE PART.</p>
05	HEATING SENSOR	<p>q. SENSOR MALFUNCTION OR INCORRECT (RESISTANCE VALUE 10 kOhms AT 25 °C). r. SENSOR CONNECTOR DISCONNECTED OR WET.</p>	<p>q. REPLACE PART. r. CHECK THE ELECTRICAL CONNECTION.</p>
06	D.H.W. SENSOR	<p>s. SENSOR MALFUNCTION OR INCORRECT (RESISTANCE VALUE 10 kOhms AT 25 °C). t. SENSOR CONNECTOR DISCONNECTED OR WET.</p>	<p>s. REPLACE PART. t. CHECK THE ELECTRICAL CONNECTION.</p>
14	WATER PRESSURE SWITCH	<p>u. WATER PRESSURE SWITCH MALFUNCTION. v. UNSTABLE ELECTRICAL CONNECTION.</p>	<p>u. REPLACE PART. v. CHECK THE ELECTRICAL CONNECTION.</p>
22	PARAMETER PROGRAMMING REQUEST	<p>w. LOSS OF MICROPROCESSOR MEMORY.</p>	<p>w. REPROGRAM PARAMETERS.</p>

## 6.8 Diagnostics

### ■ Error codes:

- 1** IONISATION BLOCK
- 2** SAFETY THERMOSTAT TRIPPED
- 4** WATER PRESSURE ALARM
- 5** HEATING SENSOR MALFUNCTION
- 6** D.H.W. SENSOR MALFUNCTION
- 14** GENERAL ALARM (AIR PRESSURE SWITCH OR WATER PRESSURE SWITCH)
- 22** PARAMETER PROGRAMMING REQUEST

### ■ Signal codes

SIGNAL CODE	SIGNAL TYPE	DESCRIPTION
<b>7</b>	CHIMNEY-SWEEP FUNCTION ACTIVE	PRESSING THE “SERVICE” BUTTON FOR 5 SECONDS ACTIVATES THE CHIMNEY-SWEEP FUNCTION. PRESSING THE BOILER OFF BUTTON DEACTIVATES THE FUNCTION. THE CHIMNEY-SWEEP FUNCTION OPERATES THE BOILER AT MAXIMUM HEATING PRESSURE FOR 15 MINUTES WITHOUT ANY MODULATION. THE FUNCTION IS USEFUL FOR COMBUSTION TESTING.
<b>8</b>	HEATING ANTI-FREEZE FUNCTION	THE FUNCTION IS ACTIVATED WHEN THE HEATING SENSOR SENSES A TEMPERATURE OF 5 °C. THE BOILER OPERATES AT MINIMUM GAS PRESSURE WITH THE DIVERTER VALVE IN THE WINTER POSITION. THE FUNCTION IS DEACTIVATED WHEN THE TEMPERATURE DETECTED BY THE SENSOR REACHES 30 °C.
<b>9</b>	D.H.W ANTI-FREEZE FUNCTION	THE FUNCTION IS ACTIVATED WHEN THE SENSOR SENSES A TEMPERATURE OF 4 °C. THE BOILER OPERATES AT MINIMUM GAS PRESSURE. THE DIVERTER VALVE CLOSSES IN THE SUMMER POSITION AND HEATS THE D.H.W CIRCUIT. THE FUNCTION IS DEACTIVATED WHEN THE D.H.W SENSOR DETECTS A TEMPERATURE OF 8°C.
<b>31</b>	INCOMPATIBLE REMOTE CONTROL.	THE FUNCTION IS ACTIVATED WHEN A RADIANT REMOTE CONTROL OR INTERFACE BOARD IS NOT PRESENT.

## 6.9 Parts list

### ■ main components

PART NUMBER	DESCRIPTION	RKA 25
20025LA	ANODE W/ CONTROL VALVE	✓
20040LA	PLATE EXCHANGER 16 P	✓
20050LA	CONDENSING EXCHANGER RKA R 4+1 GM30-75-064	✓
20051LA	CYLINDER 14 LT. RKA	✓
24029LA	CIRCULATING PUMP MOTOR RSL 15/6-3-KUCLF6	✓
24046LA	CIRCULATING PUMP RSL 15/6-3-KUCLF6 W/C1	✓
27044LA	SIPHON RK25	✓
35021LA	IGNITION ELECTRODE FOR RK GM10-35-025	✓
35022LA	FLAME IONISATION ELECTRODE FOR RK GM10-35-026	✓
36067LA	ELECTR. GAS VALVE VK4115V1006B	✓
37018LA	EXHAUST FAN 88667.11130 RG128/1300	✓
43157LP	SEALING + CLIPS KIT FOR MULTIPLEX GROUP	✓
59015LA	WATER PRESSURE SWITCH PC5411 BRASS	✓
73507LA	D.H.W.-HEATING 1/8" WHITE SENSOR S010056	✓
76654LA	DIGITAL INDICATORS P.C.B. SK06206	✓
76655LA	MAIN PRINTED CIRC. BOARD SM20015	✓
76657LA	ELECTR. IGNIT. BOARD S4565PD2020	✓
76658LA	PRINTED CIRC. BOARD SK11001	✓
86006LA	LIMIT THERMOSTAT 95gr(°)E.	✓
86014LA	WATER PRESSURE GAUGE M3A-ABS 400-4 PB120417	✓
95006LA	LT.10 EXPANSION VESSEL 490x200	✓
96008LA	HEATING CIRCUIT 3 bar PRESSURE RELIEF VALVE	✓
96032LA	DIVERTER VALVE ATV 300/13	✓
96034LA	DIVERTER VALVE ATV 300/13 MOTOR NYM-16H FOR	✓

■ MULTIPLEX unit – mod. RKA 25

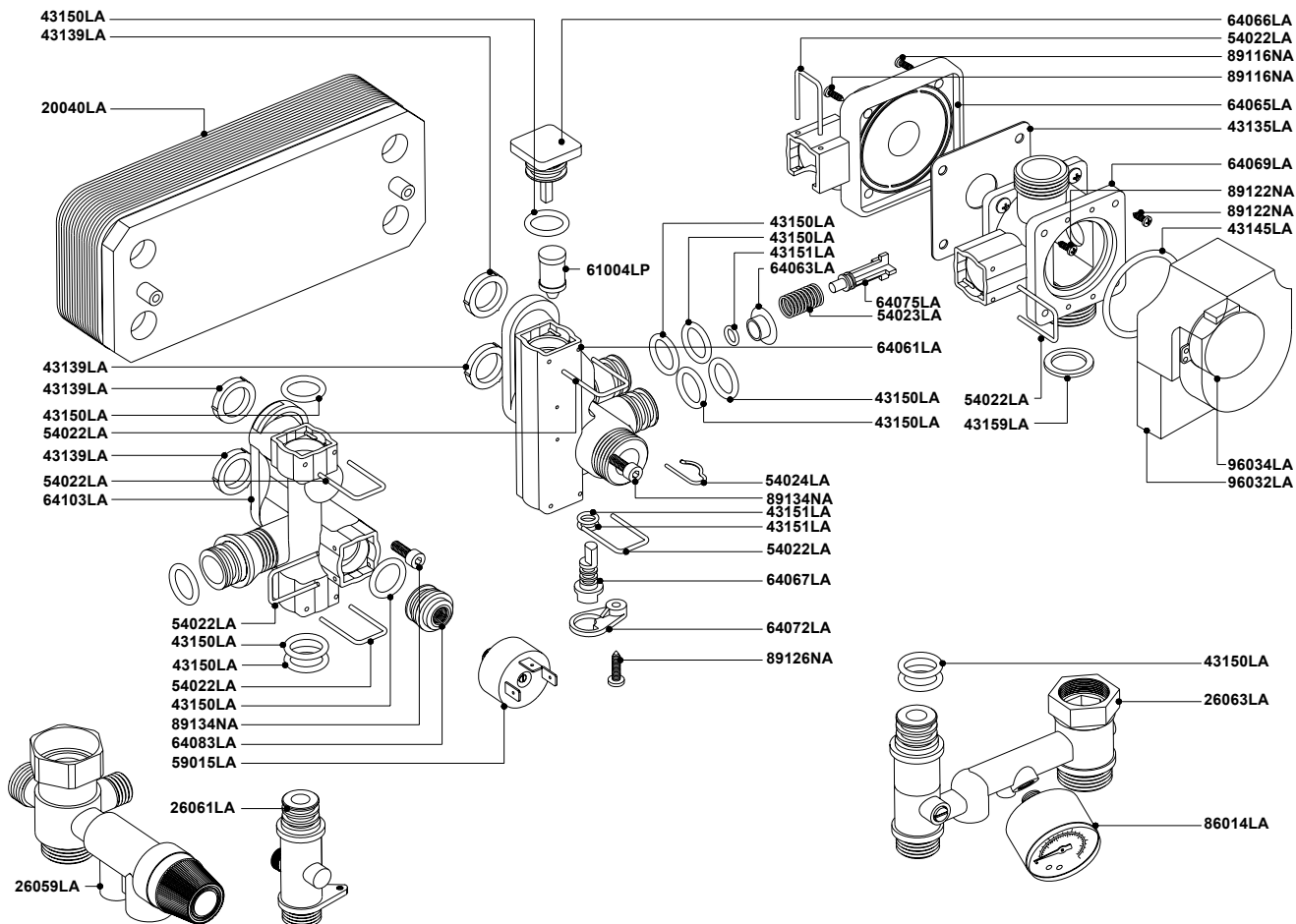

ACCESSORIES	26061LA	HOT WATER OUTLET CONNECTION RM A/S M.PLEX 2796
	26063LA	COLD WATER-HEATING FLOW CONNECTION MULTIPLEX
	26059LA	PUMP MANIFOLD MULTIPLEX 279 8
	59015LA	WATER PRESSURE SWITCH PC5411 BRASS
	73507LA	D.H.W.-HEATING 1/8" WHITE SENSOR S010056
	86014LA	WATER PRESSURE GAUGE M3A-ABS 400-4 PB120417
MULTIPLEX GROUP	20040LA	PLATE EXCHANGER 16 P
	43002LA	WASHER D.18.5x10.2x2 1/2" -AFM34
	43135LA	3-WAY VALVE FLANGE WASHER -MPLEX.
	43139LA	PLATE EXCHANGER O-RING MULTIPLEX
	43145LA	3-WAY VALVE MOTOR O-RING MULTIPLEX
	43150LA	EPDM O-RING FOR BRASS CONNECTIONS MULTIPLEX
	43151LA	BY/PASS REGULATOR EPDM O-RING 5x2 MULTIPLEX
	43159LA	WASHER EPDM 80 SH M.PLEX 16x24x2,5
	54022LA	ZINC-PLATED STEEL FIXING CLIP MULTIPLEX
	54023LA	BY PASS SPRING MULTIPLEX
	54024LA	BY PASS-REGULATOR FIXING CLIP MULTIPLEX
	61004LP	FLOWSWITCH PISTON
	64061LA	FLOWSWITCH GROUP M.PLEX - STORAGE BOILER
	64063LA	BY PASS NYLON BUSH MULTIPLEX
	64064LA	PUMP CONNECTION BODY MULTIPLEX
	64065LA	3-WAY VALVE BODY-BACK PIECE MULTIPLEX
	64066LA	FLOWSWITCH/PUMP CONNECTION CAPMULTIPLEX
	64067LA	BY PASS REGULATOR MULTIPLEX
	64069LA	3-WAY VALVE BODY-CENTRAL SEC. MPLEX STOR. MODELS
	64072LA	BY PASS FIXING PLATE MULTIPLEX
	64075LA	BY PASS MULTIPLEX
	64083LA	WATER PRESSURE SWITCH CONNECTION MULTIPLEX
	64093LA	PUMP CONN. PLUG M.PLEX 0206T1
	89025NA	SCREW 5x14 PLATE EXCHANGER
	89116NA	SCREW 5x16
	89122NA	SCREW 5x13
	89126NA	SCREW 3.9x13
	96032LA	DIVERTER VALVE ATV 300/13
	96034LA	DIVERTER VALVE MOTORE 561128 NAMY

# SIRRUS



Heating technology since 1959

## **RADIANT BRUCIATORI s.p.a.**

Via Pantanelli, 164/166 - 61025 Loc. Montelabbate (PU)  
Tel. +39 0721 9079.1 • fax. +39 0721 9079279  
e-mail: tecnico@radiant • Internet: <http://www.radiant.it>

## **RADIANT HELPLINE UK**

Technical Helpline - 0870 770 0414  
Spares - 0870 770 0425  
Email - [info@portsdean.co.uk](mailto:info@portsdean.co.uk)



***The code of practice for the installation,  
commissioning & servicing of gas fires and wall heaters***

THE TECHNICAL DATA AND MEASUREMENTS ARE PROVIDED FOR INFORMATION PURPOSES ONLY AND ARE NOT BINDING. THE COMPANY RESERVES THE RIGHT TO APPLY VARIATIONS WITHOUT PRIOR NOTIFICATION. NEITHER WILL THE COMPANY BE HELD RESPONSIBLE FOR ANY INACCURACIES IN THIS HANDBOOK DERIVING FROM PRINTING OR TRANSLATION ERRORS. E+OEALL RIGHTS RESERVED. NO PART OF THIS DOCUMENT MAY BE REPRODUCED, MEMORISED IN ANY FILING SYSTEMS OR TRANSMITTED IN ANY FORM WHATSOEVER, INCLUDING ELECTRONIC, MECHANICAL, PHOTOCOPIES, RECORDINGS OR ANY OTHER MEANS WITHOUT THE COMPANY'S PRIOR WRITTEN APPROVAL.

**TG05A095.A0306**